

**581**

**583**

INSTRUCTION MANUAL

This instruction manual applies to machines  
from the following serial numbers onwards:

# 2 771 790 →



This Instruction Manual is valid for all models and subclasses listed in the chapter "Specifications".



The adjustment manual for the machines can be downloaded free of charge from the internet address

**[www.pfaff-industrial.com/pfaff/de/service/downloads](http://www.pfaff-industrial.com/pfaff/de/service/downloads)**

As an alternative to the internet download the adjustment manual can also be ordered in book form under part no. **296-12-19 140/002**.

The reprinting, copying or translation of PFAFF Instruction Manuals, whether in whole or in part, is only permitted with our previous authorization and with written reference to the source.

**PFAFF Industriesysteme  
und Maschinen AG**

Hans-Geiger-Str. 12 - IG Nord  
D-67661 Kaiserslautern

	Contents .....	Page
<b>1</b>	<b>Safety .....</b>	<b>5</b>
1.01	Directives .....	5
1.02	General notes on safety .....	5
1.03	Safety symbols .....	6
1.04	Important points for the user .....	6
1.05	Operating and specialist personnel .....	7
1.05.01	Operating personnel .....	7
1.05.02	Specialist personnel .....	7
1.06	Danger warnings .....	8
<b>2</b>	<b>Proper use.....</b>	<b>9</b>
<b>3</b>	<b>Specifications .....</b>	<b>10</b>
3.01	PFAFF 581, PFAFF 583 .....	10
3.02	Versions and subclasses .....	11
<b>4</b>	<b>Disposal of Machine .....</b>	<b>12</b>
<b>5</b>	<b>Transportation, packing and storage.....</b>	<b>13</b>
5.01	Transportation to customer's premises .....	13
5.02	Transportation inside the customer's premises .....	13
5.03	Disposal of packing materials .....	13
5.04	Storage .....	13
<b>6</b>	<b>Explanation of symbols.....</b>	<b>14</b>
<b>7</b>	<b>Controls .....</b>	<b>15</b>
7.01	On/off switch .....	15
7.02	Pedal .....	15
7.03	Raising the presser foot.....	16
7.04	Feed regulator disk / Reverse feed lever.....	16
7.05	Keys on the machine head (only for machines with -911/..) .....	17
7.06	Control panel.....	17
<b>8</b>	<b>Installation and commissioning .....</b>	<b>18</b>
8.01	Installation.....	18
8.01.01	Adjusting the table-top height.....	18
8.01.02	Assemble the mounted motor.....	19
8.01.03	Fit the belt guard of the flange-motor .....	19

	Contents .....	Page
	<b>Contents .....</b>	<b>Page</b>
8.01.04	Mounting the sewing head.....	20
8.01.05	Mount upper machine cover.....	20
8.01.06	Mounting the spool holder .....	21
8.02	Connecting the plug-in connections and earth cables .....	21
8.03	Commissioning the machine .....	22
8.04	Switching the machine on/off .....	22
8.05	Basic position of the machine drive unit .....	23
8.05.01	On machines with PicoDrive and control unit P41 PD1 .....	23
8.05.02	With drive system MD-4-58-220-CE .....	23
8.06	Mount and connect approach barrier .....	24
8.07	Checking the start inhibitor function.....	24
<b>9</b>	<b>Preparation .....</b>	<b>25</b>
9.01	Inserting the needle.....	25
9.02	Winding the bobbin thread, adjusting the thread tension.....	26
9.03	Removing / Inserting the bobbin case .....	27
9.04	Inserting the bobbin case / Adjusting the bobbin thread tension.....	27
9.05	Threading the needle thread / Adjusting the needle thread tension .....	28
<b>10</b>	<b>Care and maintenance.....</b>	<b>29</b>
10.01	Servicing and maintenance intervals .....	29
10.02	Cleaning the machine .....	29
10.03	Topping up the oil tank.....	30
10.04	Parameter settings.....	31
10.04.01	Parameter list for PicoDrive with control unit P41 PD2 .....	31
10.04.02	Parameter list for drive system MD-4-58-220-CE .....	32
<b>11</b>	<b>Mounting the table top .....</b>	<b>33</b>
11.01	Table top cutout .....	33
11.02	Mounting the table top (with drive system MD-4-58-220-CE) .....	34
11.03	Mounting the table top (with PicoDrive and control unit P41 PD2) .....	35
<b>12</b>	<b>Block diagram .....</b>	<b>36</b>
12.01	PFAFF 581 + 583 with MD-4-58-220-CE .....	36
12.02	PFAFF 581 + 583 with PicoDrive and control unit P41 PD2 .....	37
<b>13</b>	<b>Wearing parts.....</b>	<b>38</b>

## 1 Safety

### 1.01 Directives

The machine has been constructed in accordance with the requirements listed in the EC Declaration of Conformity and the Declaration of Incorporation.

In addition to this Instruction Manual, also observe all generally accepted, statutory and other regulations and legal requirements and all valid environmental protection regulations! The regionally valid regulations of the social insurance society for occupational accidents or other supervisory organizations are to be strictly adhered to!

### 1.02 General notes on safety

- This machine may only be operated by adequately trained operators and only after having completely read and understood the Instruction Manual!
- All Notes on Safety and Instruction Manuals of the motor manufacturer are to be read before operating the machine!
- The danger and safety instructions on the machine itself are to be followed!
- This machine may only be used for the purpose for which it is intended and may not be operated without its safety devices. All safety regulations relevant to its operation are to be adhered to.
- When exchanging sewing tools (e.g. needle, roller presser, needle plate and bobbin), when threading the machine, when leaving the machine unattended and during maintenance work, the machine is to be separated from the power supply by switching off the On/Off switch or by removing the plug from the mains!
- Everyday maintenance work is only to be carried out by appropriately trained personnel!
- Repairs and special maintenance work may only be carried out by qualified service staff or appropriately trained personnel!
- Work on electrical equipment may only be carried out by appropriately trained personnel!
- Work is not permitted on parts and equipment which are connected to the power supply! The only exceptions to this rule are found in the regulations EN 50110.
- Modifications and alterations to the machine may only be carried out under observance of all the relevant safety regulations!
- Only spare parts which have been approved by us are to be used for repairs! We expressly point out that any replacement parts or accessories which are not supplied by us have not been tested and approved by us. The installation and/or use of any such products can lead to negative changes in the structural characteristics of the machine. We are not liable for any damage which may be caused by non-original parts.

## 1.03 Safety symbols



Danger!  
Points to be observed.



Danger of injury for operating and specialist personnel!



### Caution

Do not operate without finger guard and safety devices.  
Before threading, changing bobbin and needle, cleaning etc. **switch off main switch.**

## 1.04 Important points for the user

- This Instruction Manual is an integral part of the machine and must be available to the operating personnel at all times.
- The Instruction Manual must be read before operating the machine for the first time.
- The operating and specialist personnel is to be instructed as to the safety equipment of the machine and regarding safe work methods.
- It is the duty of the user to only operate the machine in perfect running order.
- It is the obligation of the user to ensure that none of the safety mechanisms are removed or deactivated.
- It is the obligation of the user to ensure that only authorized persons operate and work on the machine.

Further information can be obtained from your PFAFF agent.

## 1.05 Operating and specialist personnel

### 1.05.01 Operating personnel

Operating personnel are persons responsible for the equipping, operating and cleaning of the machine as well as for taking care of problems arising in the sewing area.

The operating personnel is required to observe the following points and must:

- always observe the Notes on Safety in the Instruction Manual!
- never use any working methods which could adversely affect the safety of the machine!
- not wear loose-fitting clothing or jewelery such as chains or rings!
- also ensure that only authorized persons have access to the potentially dangerous area around the machine!
- always immediately report to the person responsible any changes in the machine which may limit its safety!

### 1.05.02 Specialist personnel

Specialist personnel are persons with a specialist education in the fields of electrics, electronics and mechanics. They are responsible for the lubrication, maintenance, repair and adjustment of the machine.

The specialist personnel is obliged to observe the following points and must:

- always observe the Notes on Safety in the Instruction Manual!
- switch off the On/Off switch before carrying out adjustments or repairs, and ensure that it cannot be switched on again unintentionally!
- wait until the luminous diode on the control box is no longer blinking or on before beginning adjustment or repair work.
- never work on parts which are still connected to the power supply! Exceptions are explained in the regulations EN 50110.
- replace the protective coverings and close the electrical control box after all repairs or maintenance work!

## 1.06

### Danger warnings



A working area of 1 m must be kept free both in front of and behind the machine, so that easy access is possible at all times.



Never put your hands or fingers in the sewing area during sewing!  
Danger of injury by the needle!



While setting or adjusting the machine do not leave any objects on the table nor in the needle plate area! Objects may be trapped or flung out of the machine!

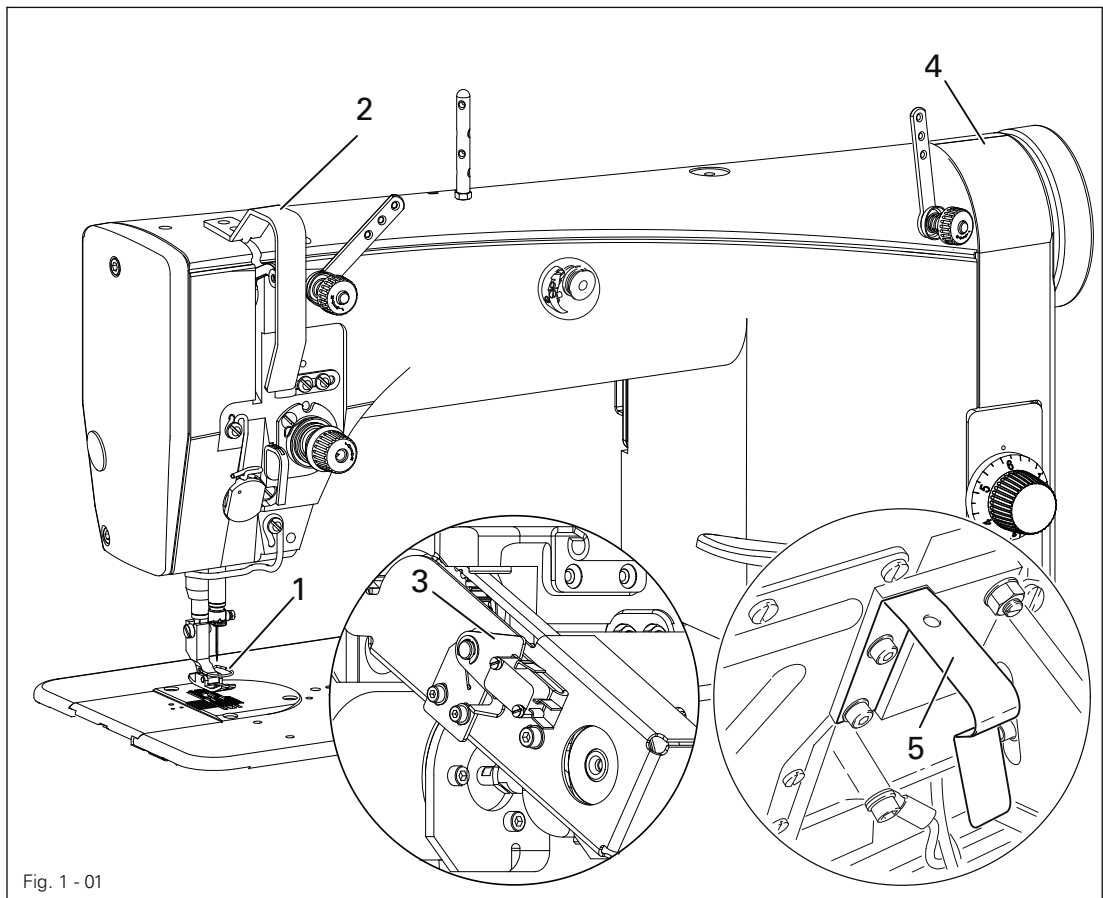

Fig. 1 - 01



Do not run the machine without finger guard **1!**  
Danger of injury by up and down movement of needle!



Do not run the machine without take-up lever guard **2!**  
Danger of injury by moving take-up lever!



Do not operate without start inhibitor **3!**  
Danger of injury if the machine is started accidentally!



Do not operate the machine without machine cover **4!**  
Danger of injury from moving parts!



Do not operate the machine without tilt lock **5!**  
Danger of crushing between sewing head and table!



2

**Proper use**

The PFAFF 581 is an single-needle ultra-high-speed seamer with compound feed

The PFAFF 583 is an single-needle ultra-high-speed seamer with drop feed

These machines are used in the industry for sewing lockstitch seams.



Any and all uses of this machine which have not been approved of by the manufacturer are considered to be inappropriate! The manufacturer cannot be held liable for any damage caused by the inappropriate use of the machine!

The appropriate use of the machine includes the observance of all operational, adjustment, maintenance and repair measures required by the manufacturer!

## 3 Specifications ▲

### 3.01 PFAFF 581, PFAFF 583

Stitch type: .....301 ( lockstitch )

Needle system: ..... 134

Needle size in 1/100 mm:

Version A: ..... 60 - 70

Version B: ..... 80 - 100

Version C: ..... 110 - 140

Fabric clearance: ..... 9 - 13 mm

Clear workspace width: ..... 260 mm

Clear workspace height: ..... 130 mm

Bed-plate dimensions: ..... 476 x 177 mm

Sewing head dimensions:

Length: ..... approx. 550 mm

Width: ..... approx. 180 mm

Height (above table): ..... approx. 300 mm

Max. stitch length: ..... 6 mm

Max. speed

Version A: ..... 5500 spm

Version B: ..... 5500 spm

Version C: ..... 5000 spm

Subclass -944/07: ..... 3500 spm

Power connection:

Operating voltage: ..... 230 V ± 10 %, 50/60 Hz, single-phase

Max. input: ..... 400 VA

Fuse: ..... 1 x 16 A, inert

Noise data:

Noise emission level at workplace with a sewing speed of 4800 spm: .....  $L_{pA} < 82$  dB(A)■

(Noise measurement in accordance with DIN 45 635-48-A-1, ISO 11204, ISO 3744, ISO

Net weight of sewing head: ..... approx. 40 kg

Gross weight of sewing head: ..... approx. 48 kg

▲ Subject to technical alterations

■  $K_{pA} = 2,5$  dB

**3.02 Versions and subclasses**

Version A: ..... for sewing light materials  
Version B: ..... for sewing medium materials  
Version C: ..... for sewing medium-heavy materials

**Work aids:**

Subclass -900/.. ..... thread trimmer  
Subclass -909/.. ..... Thread trapper  
Subclass -910/.. ..... automatic foot lift  
Subclass -911/.. ..... automatic back-tacking mechanism

4

### Disposal of Machine

- Proper disposal of the machine is the responsibility of the customer.
- The materials used for the machine are steel, aluminium, brass and various plastic materials. The electrical equipment comprises plastic materials and copper.
- The machine is to be disposed of according to the locally valid pollution control regulations; if necessary, a specialist is to be commissioned.



Care must be taken that parts soiled with lubricants are disposed of separately according to the locally valid pollution control regulations!

### **5 Transportation, packing and storage**

#### **5.01 Transportation to customer's premises**

The machines are delivered completely packed.

#### **5.02 Transportation inside the customer's premises**

The manufacturer cannot be made liable for transportation inside the customer's premises nor to other operating locations. It must be ensured that the machines are only transported in an upright position.

#### **5.03 Disposal of packing materials**

The packing materials of this machine comprise paper, cardboard and VCE fibre. Proper disposal of the packing material is the responsibility of the customer.

#### **5.04 Storage**

If the machine is not in use, it can be stored as it is for a period of up to six months, but it should be protected against dust and moisture.

If the machine is stored for longer periods, the individual parts, especially the surfaces of moving parts, must be protected against corrosion, e.g. by a film of oil.

### 6 Explanation of symbols

In this instruction manual, work to be carried out or important information is accentuated by symbols. These symbols have the following meanings:



Note, information



Cleaning, care



Lubrication

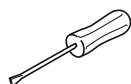

Maintenance, repairs, adjustment, service work  
(only to be carried out by technical staff)

7 Controls

7.01 On/off switch

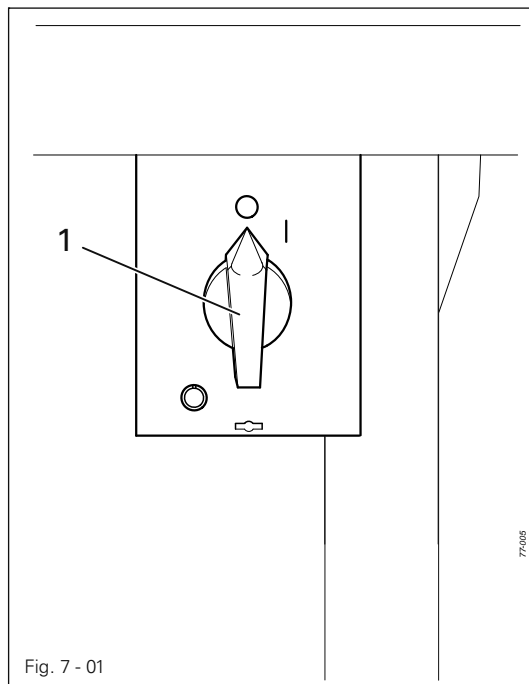

- The power supply to the machine is switched on or off by turning switch 1.

7.02 Pedal

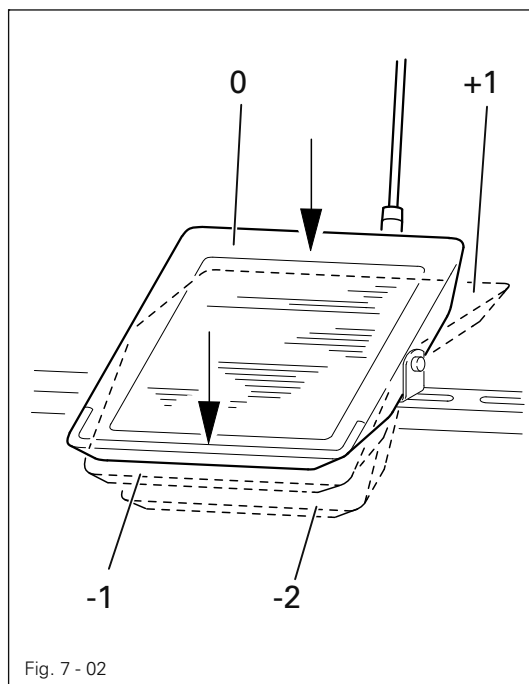

- With the on/off switch on
  - 0 = Machine stop
  - +1 = Sew
  - 1 = Raise presser foot (for machines with -910/..)
  - 2 = Trim thread (for machines with -900/..)

## 7.03 Raising the presser foot

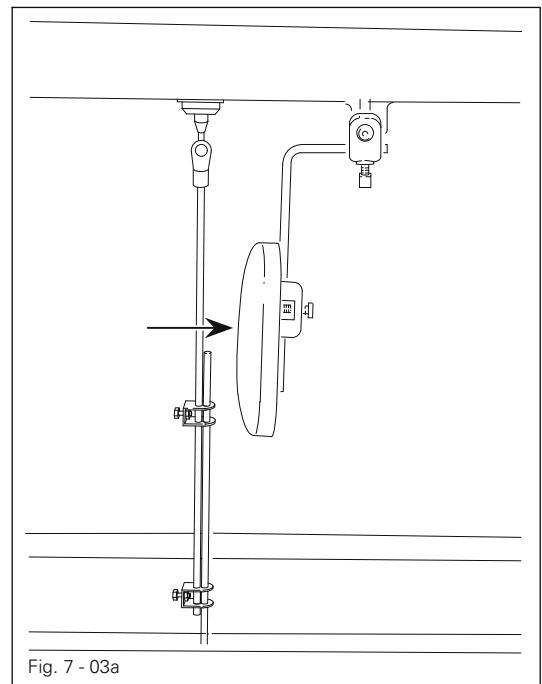
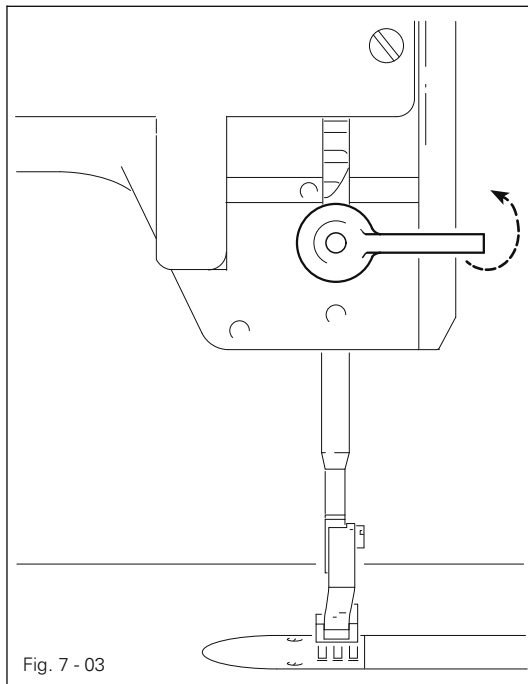

## 7.04 Feed regulator disk / Reverse feed lever

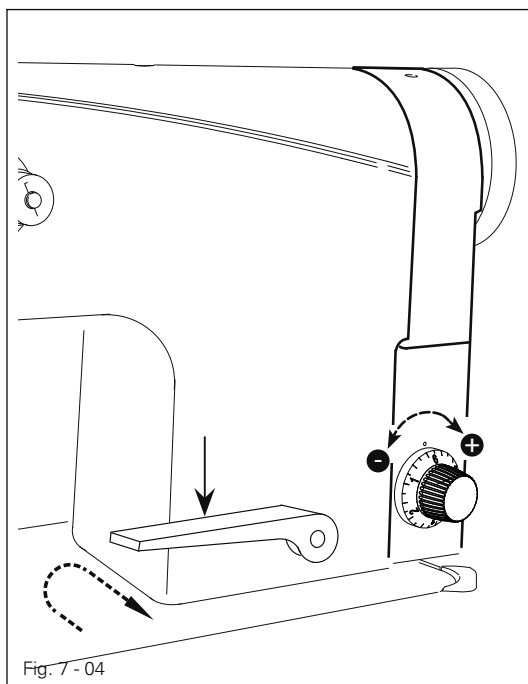



## 7.05 Keys on the machine head (only for machines with -911/..)

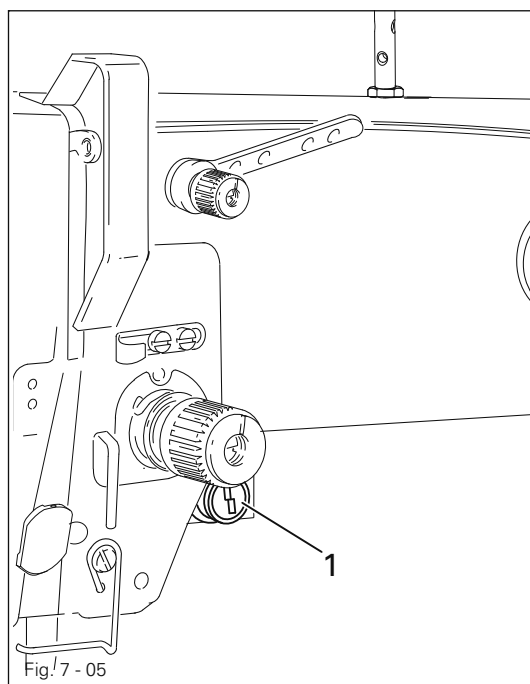

- As long as key 1 is pressed during sewing, the machine sews in reverse.

## 7.06 Control panel

The description can be found in the separate instruction manual for the motor.

## 8 Installation and commissioning

The machine must only be mounted and commissioned by qualified personnel!  
All relevant safety regulations are to be observed!



If the machine is delivered without a table, it must be ensured that the frame and the table top which you intend to use can hold the weight of the machine and the motor. It must be ensured that the supporting structure is sufficiently sturdy, including during all sewing operations.

### 8.01 Installation

The site where the machine is installed must be provided with suitable connections for the electric current, see Chapter 3 Specifications.

It must also be ensured that the standing surface of the machine site is firm and horizontal, and that sufficient lighting is provided.



The method of packaging used requires that the table top be lowered for transport. The following is a description of how to adjust the height of the table top.

#### 8.01.01 Adjusting the table-top height

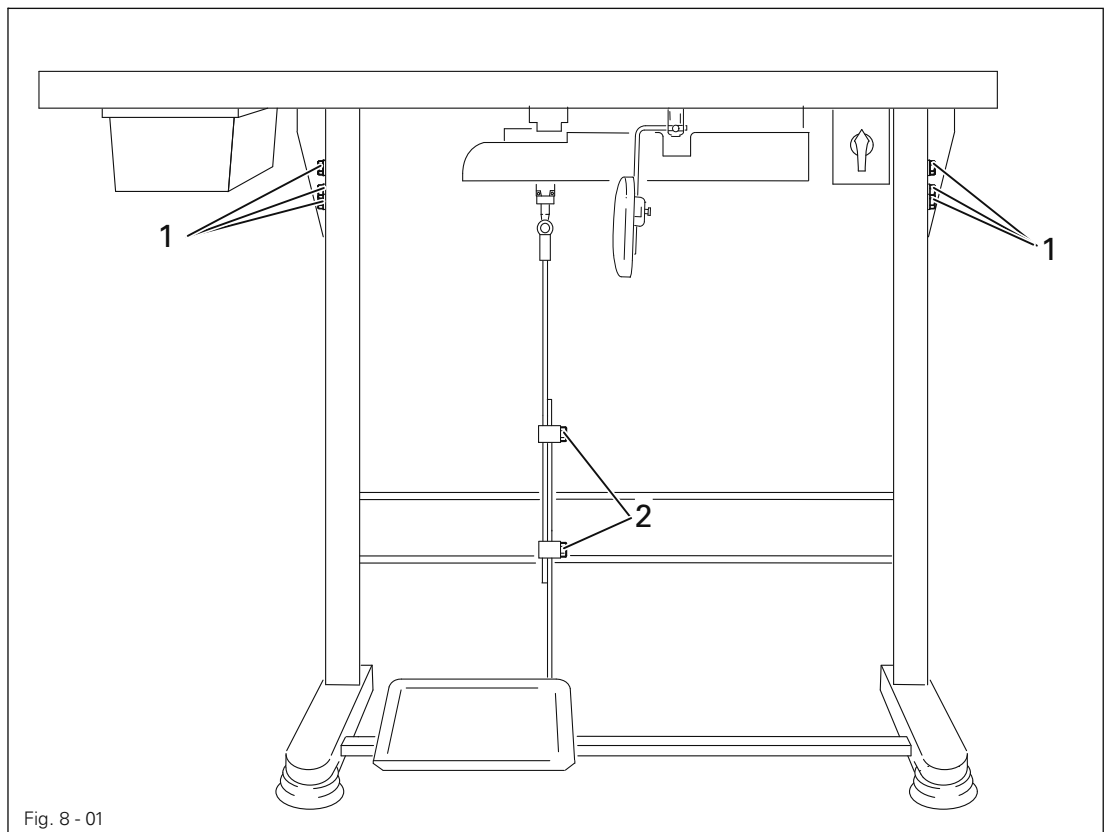
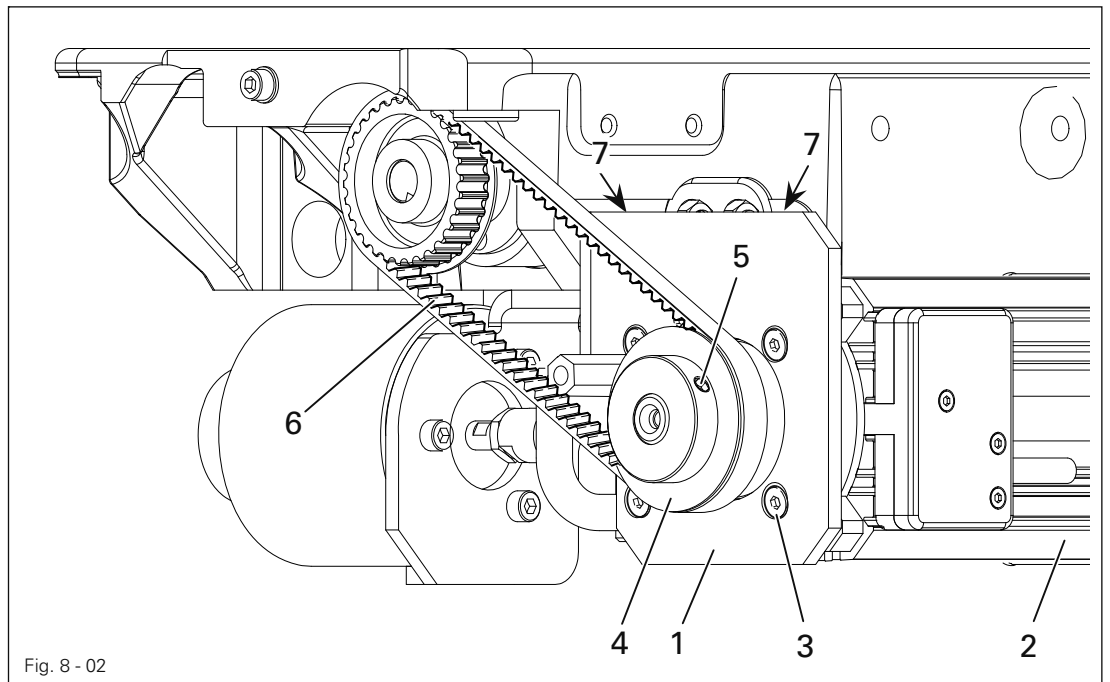

Fig. 8 - 01

- Loosen screws 1 and 2 and set the desired table-top height
- Tighten screws 1 well.
- Adjust the position of the pedal so that you can operate it comfortably and tighten screw 2.

## 8.01.02 Assemble the mounted motor



- Fix bearing plate 1 on to motor 2 using screws 3, as shown in fig. 8-02.
- Mount drive belt wheel 4 onto motor shaft and attach with screws 5.
- Tilt bearing plate 1 with motor 2 slightly to the side and lay drive belt 6 onto the drive belt wheels.
- Align bearing plate 1 of motor 2 with machine housing and attach with screws 7.
- Tighten drive belt by pivoting the motor, loosen screws 3 slightly to do so.

## 8.01.03 Fit the belt guard of the flange-motor

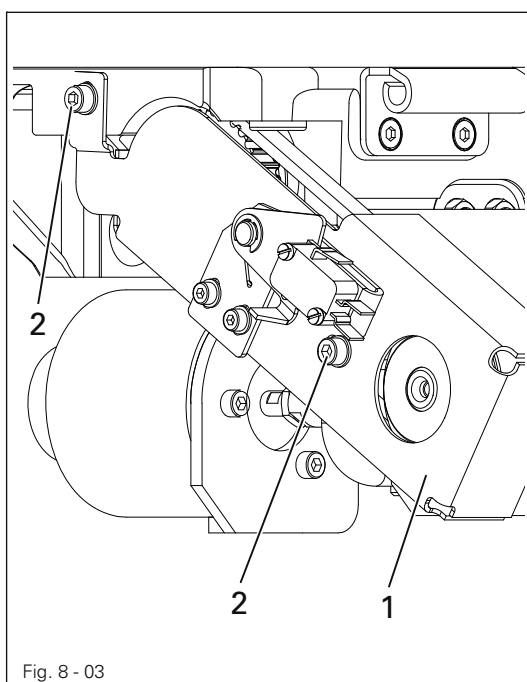

- Attach belt guard 1 with screws 2.

## 8.01.04 Mounting the sewing head

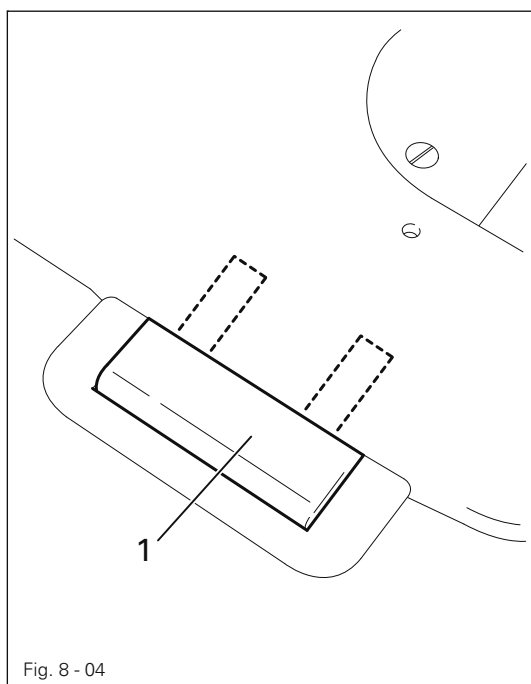

- Attach the hinges **1** with two screws each in the relevant bore holes on the base plate.
- Insert the sewing head with hinges **1** into the rear rubber pads.

## 8.01.05 Mount upper machine cover

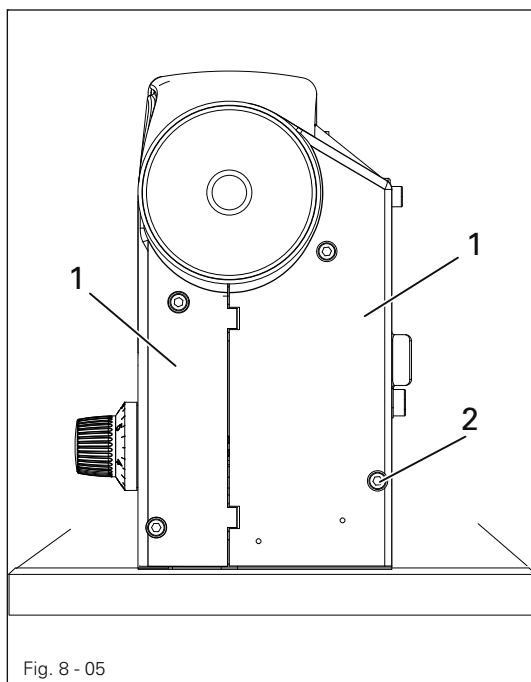

- Attach machine cover **1** with screws **2**.

## 8.01.06 Mounting the spool holder

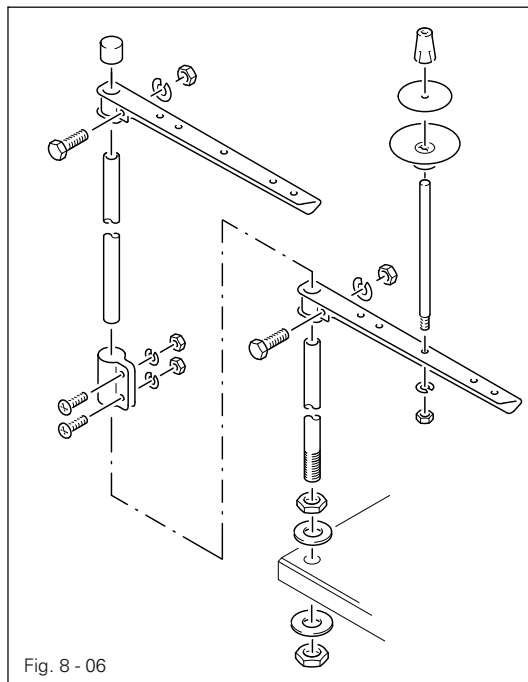

- Mount the spool holder as shown in Fig. 8-08.
- Insert the spool holder into the hole in the table top and fasten it with the nuts enclosed.

## 8.02 Connecting the plug-in connections and earth cables

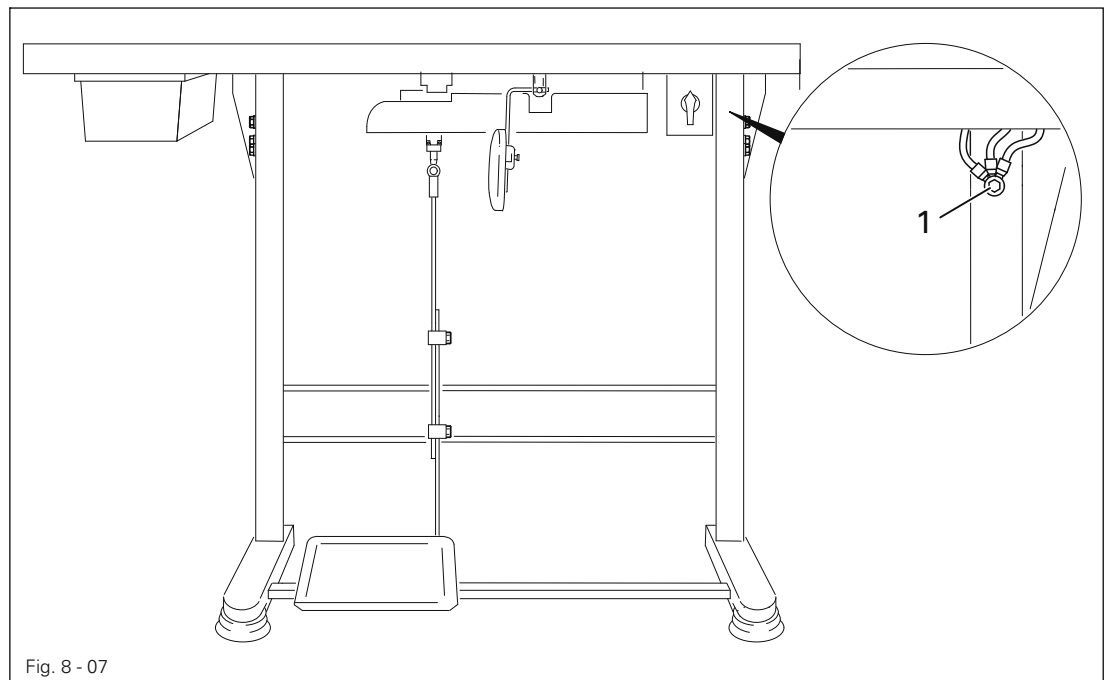

- Connect all plug connections as described in the operations manual of the drive
- The following ground cables must be attached in order to discharge static electricity.
- Attach ground cables for machine, main switch, control unit and motor to ground point 1.

## 8.03 Commissioning the machine

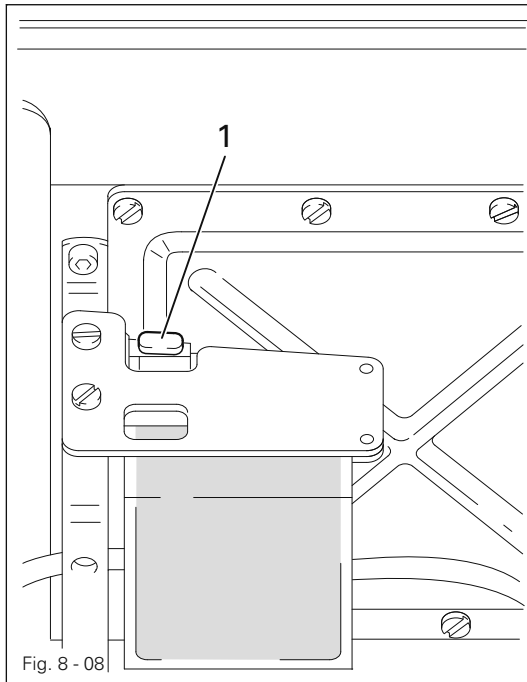

- Check machine and in particular electric lines for damage before first commissioning.
- Remove pin 1 of the oil reservoir 2 (Fig. 8 - 08).

The pin serves only to protect the machine from damage during transport and must not be used when sewing.



- Clean the machine thoroughly and oil it (see chapter 10 Care and maintenance).
- Have skilled personnel check if the machine can be operated with the available mains voltage.



Do not operate the machine if there is any discrepancy.  
The machine may only be connected to an earthed socket!



Have home position of the machine drive verified by certified technicians before first commissioning! Have settings carried out by technicians where required (see chapter 8.05)

## 8.04 Switching the machine on/off

- Switch the machine on (see Chapter 7.01, On/off switch).

## 8.05 Basic position of the machine drive unit

### 8.05.01 On machines with PicoDrive and control unit P41 PD2

- Switch on the machine.
- Call up the parameter input by pressing the "scroll" key.
- To switch the function keys to input (LED in the TE key lights up), press the TE key.
- By pressing the corresponding +/- keys, select parameter "798" and service level C, see Chapter **Selecting the User Level** in the separate Control Panel Instruction Manual.
- Select parameter "799" by pressing the corresponding +/- keys.
- Check whether the value is set at "7" and alter if necessary.
- By pressing the corresponding +/- key, select parameter "700"
- Sew a stitch by operating the pedal.
- Turn the balance wheel in the sewing direction until the descending needle is level with the top edge of the needle plate.
- Conclude the adjustment of the sewing motor by pressing the "scroll" key

### 8.05.02 With drive system MD-4-58-220-CE



- Press and hold button and switch on machine
- Parameter 176 is displayed.



- Call up parameter 181.



- Call up input level.
- Sew a stitch with the pedal function.
- Turn the handwheel in rotational direction until the needle point (approaching from above) is on the upper edge of the needle plate.



- Confirm entry.



- Call up parameter 192.



Call up input level.



Press button D+ to turn function "off".



Press button "S" to exit input.

## 8.06 Mount and connect approach barrier

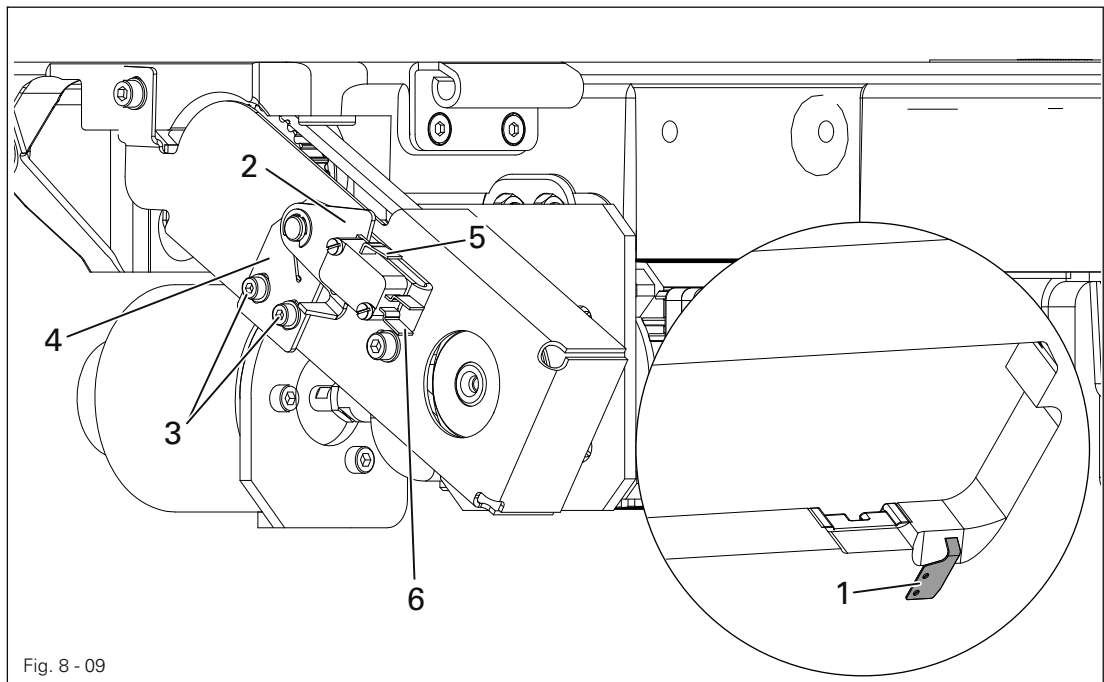

- For machines delivered without table, plate **1** (included in the accessories) must be mounted underneath the table top in such a way that the switching plate **2** is flush with plate **1** when the sewing head is tilted upright.
- Loosen screws **3** and align carrier **4** in such a way that switching plate **2** is free when the sewing head is on its side, and pressed, when the sewing head is upright.
- Connect connectors of the approach barrier on contacts **5** (red/blue) and **6** (grey/pink).

## 8.07 Checking the start inhibitor function

- Switch the machine on at the main switch and tilt back the sewing head.
- The error message "Er 0 16" (on MD-4-58-220-CE) or "Error 9" (on PicoDrive P41 PD2) must appear on the control panel.
- If the message does not appear, check the setting of safety switch **2**.
- After the sewing head has been returned to the upright position, the machine is ready for operation again.



9 Preparation



All regulations and instructions in this Instruction Manual are to be observed!  
Special attention is to be paid to the safety regulations!



All preparation work is only to be carried out by appropriately trained personnel.  
Before all preparation work, the machine is to be separated from the electricity supply by removing the plug from the mains or switching off the On/Off switch!

9.01 Inserting the needle

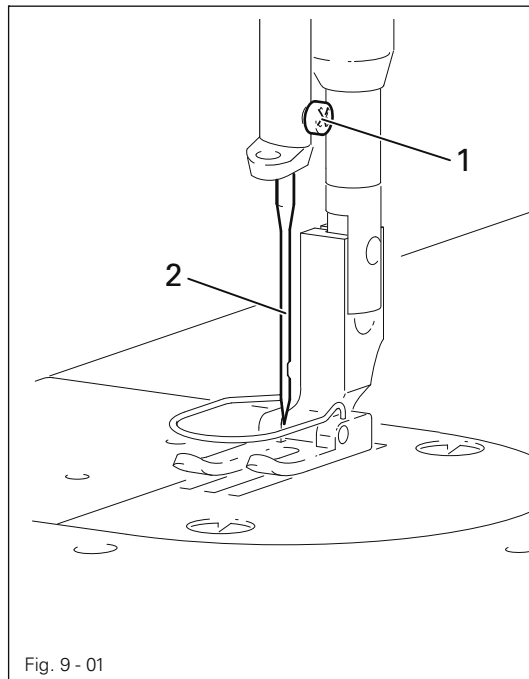

Switch off the machine!  
Danger of injury due to unintentional starting of the machine!



Only use needles from the system intended for the machine, see Chapter 3 Specifications.

- Raise needle bar.
- Loosen screw 1 and insert needle 2 until you feel it stop.
- The long needle groove must be aligned in the direction of the machine head.
- Tighten screw 1.

## 9.02 Winding the bobbin thread, adjusting the thread tension

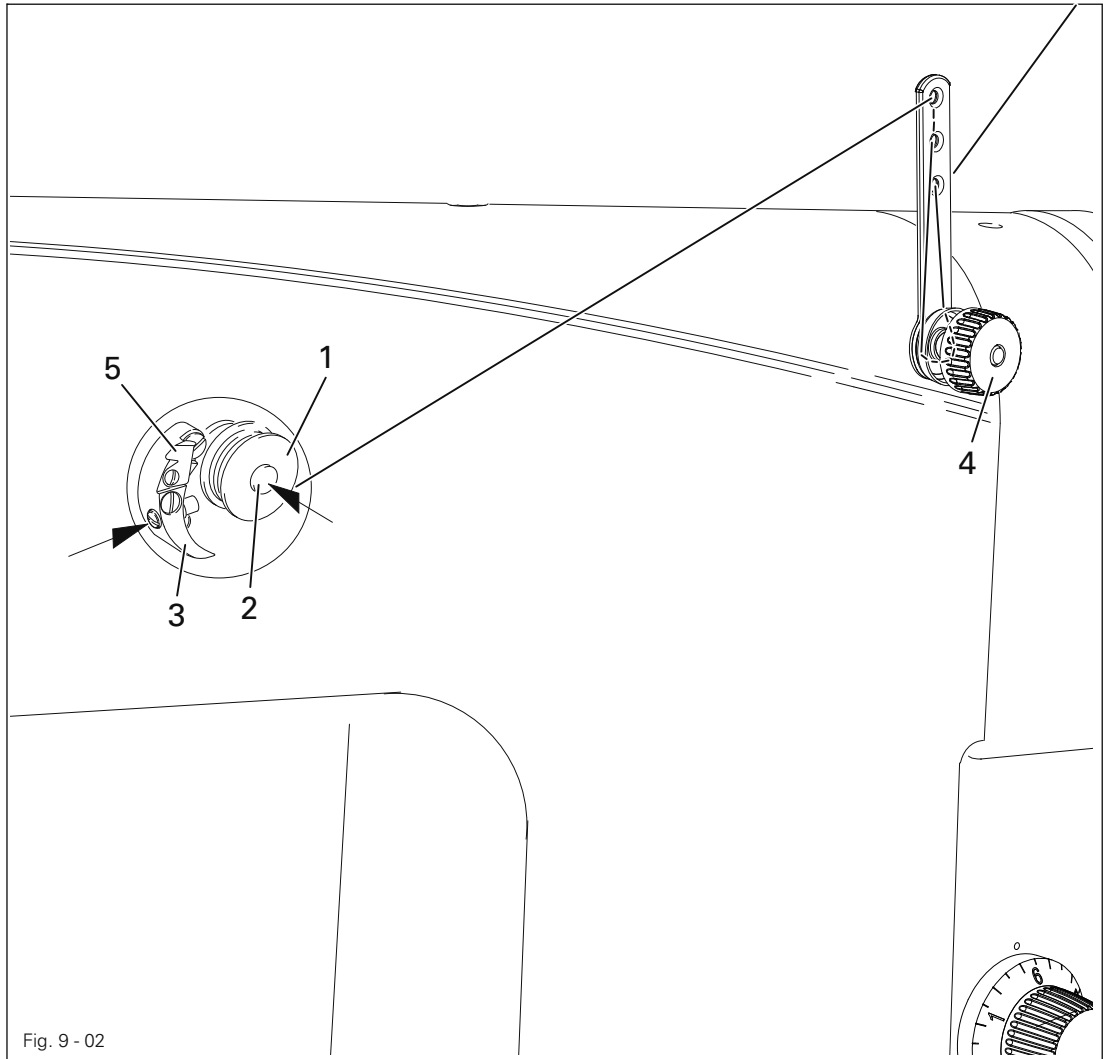

Fig. 9 - 02

- Place an empty bobbin 1 onto bobbin shaft 2.
- Thread the bobbin in accordance with Fig. 9-02 and wind it clockwise around bobbin 1 a few times.
- Switch on the bobbin winder while at the same time pressing bobbin winder spindle 2 and lever 3.



The bobbin fills up during sewing.

- The tension of the thread on bobbin 1 can be adjusted with knurled screw 4.
- The bobbin winder stops automatically when bobbin 1 is full.
- Remove the filled bobbin 1 and cut the thread on knife 5.

9.03 Removing / Inserting the bobbin case

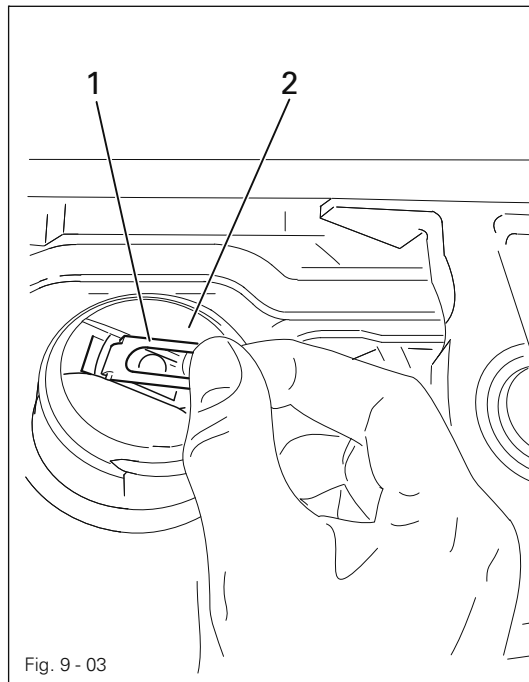

Switch off the machine!  
 Danger of injury due to unintentional starting of the machine!

**Removing the bobbin case:**

- Tilt back the machine.
- Raise latch 1 and remove bobbin case 2.

**Inserting the bobbin case:**

- Press bobbin case 2 until you feel it snap into the bobbin case base.

9.04 Inserting the bobbin case / Adjusting the bobbin thread tension

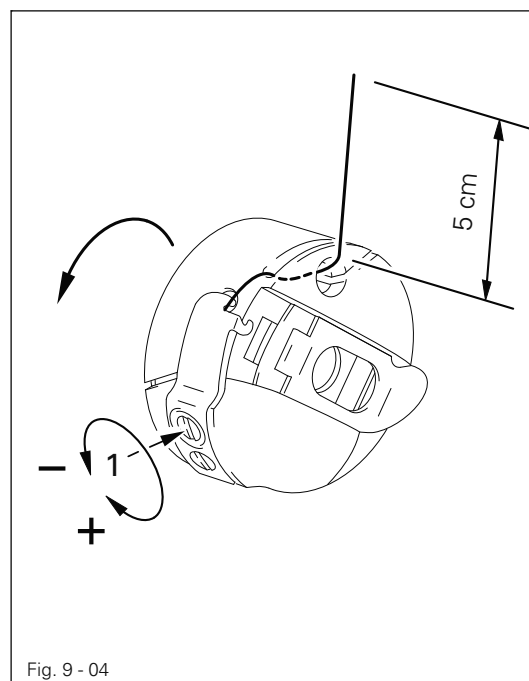

- Insert the bobbin into the bobbin case.
- Pass the thread through the slot under the spring according to Fig. 9-04.
- Pass the thread through the notch.
- Adjust the thread tension by turning screw 1.



When the thread is pulled, the bobbin must rotate in the direction of the arrow.

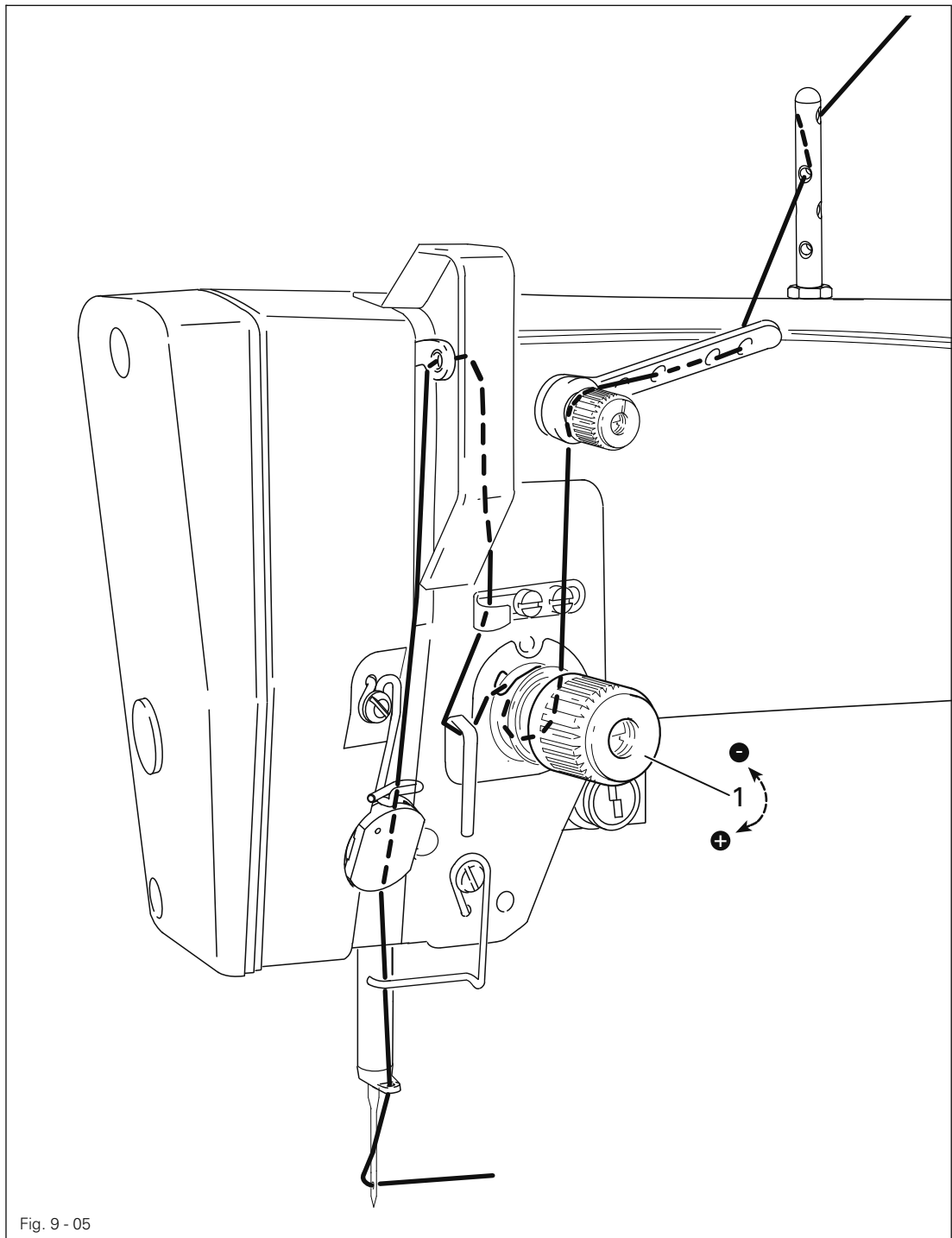

Switch off the machine!

Danger of injury due to unintentional starting of the machine!

- Thread the machine as shown in Fig. 9-05.
- Adjust the needle thread tension by turning disk 1.

10 Care and maintenance

10.01 Servicing and maintenance intervals

Clean the hook compartment .....	Daily, several times if in continuous use
Clean the entire machine .....	once a week
Check oil level .....	once a month



These maintenance intervals are calculated for the average running time of a single shift operation. If the machine is operated more than this, shorter intervals are recommended.

10.02 Cleaning the machine

The cleaning cycle required for the machine depends on following factors:

- Single or several shift operation
- Amount of dust resulting from the workpiece

It is therefore only possible to stipulate the best possible cleaning instructions for each individual case.



For all cleaning work the machine must be disconnected from the mains by switching off the on/off switch or by removing the mains plug!  
Danger of injury if the machine suddenly starts up .

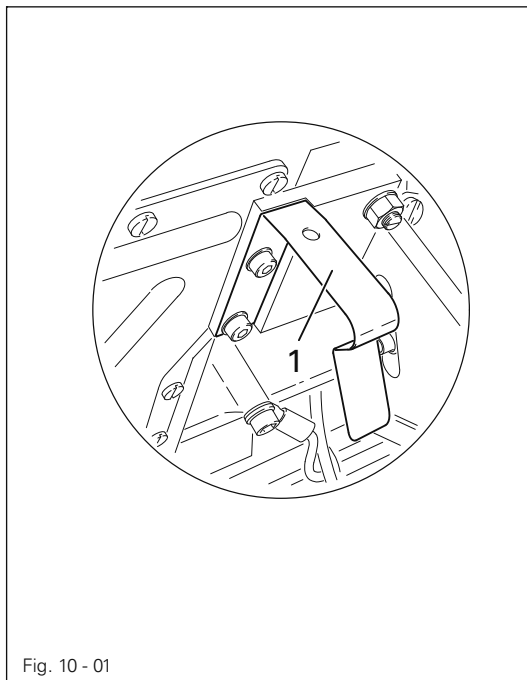

The following tasks are recommended during single shift operation to avoid operational errors:

- Tilt machine backwards.
- Clean the clamps and clamp area daily, or more often during long-term usage.
- When righting the sewing head, ensure pressing the anti-tipping device 1.

Return the machine to its upright position using **both** hands!  
Danger of injury by crushing between the edge of the machine and the table top!



### 10.03 Topping up the oil tank

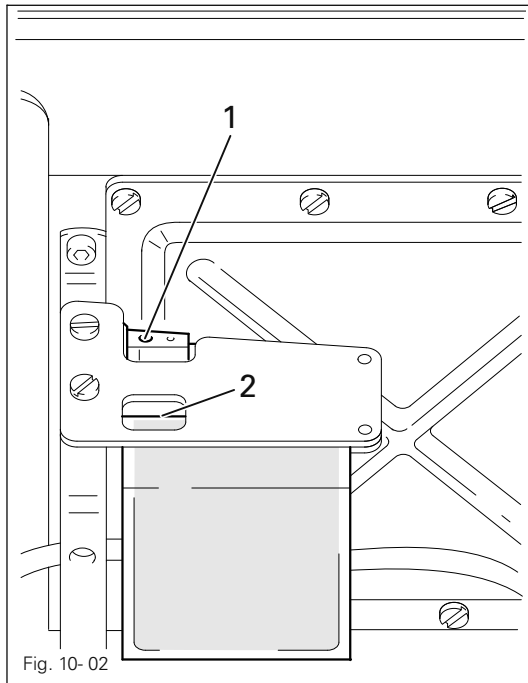

The oil reservoir must always have oil in it.

- If necessary fill oil into hole 1 up to the marking 2.



Use **both** hands to set the sewing head upright!

Danger of crushing between the sewing head and the table top!



Only use oil with a mean viscosity of  $22.0 \text{ mm}^2/\text{s}$  at  $40^\circ\text{C}$  and a density of  $0.865 \text{ g/cm}^3$  at  $15^\circ\text{C}$ .

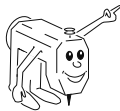

We recommend PFAFF sewing machine oil, part no. 280-1-120 144.

10.04 Parameter settings



Parameter settings are described in the separate operations manual for the drive, and may only be changed by qualified technicians!

10.04.01 Parameter list for PicoDrive with control unit P41 PD2

Group	Parameter	Description	User level	Setting range	Set value
1	105	Speed for start backtackl	B, C	300 - 2000	1400
	110	Speed for end backtack	B, C	300 - 2000	1400
6	606	Speed min	B, C	30 - 300	180
	607	Speed max.	B, C	300 - 6000	▲
	609	Cutting speed 1	B, C	60 - 300	220
	668	Thread wiper/thread blower 1 = on; 0 = off	B, C	0 - 1	0
7	700	Needle position 0 (needle reference position)	B, C	0 - 255	*
	702	Needle position 1 (needle lowered)	B, C	0 - 255	79
	703	Needle position 2 (take-up lever raised)	B, C	0 - 255	222
	705	Needle position 5 (end cutting signal 1)	B, C	0 - 255	175
	706	Needle position 5 (start cutting signal 2)	B, C	0 - 255	135
	707	Needle position 9 (start thread tension release/start thread catcher)	B, C	0 - 255	190
	797	Hardwaretest (OFF / ON ),	B, C		OFF
	799	Selected machine class	C	1 - 7	7
8	800	Rotating direction of the motor	C	0 - 1	1
	802	Main drive reduction ratio 0 = 1:1, 1 = variable	C	0 - 1	0
9	985	Switch on angle for thread trapper	B, C	0 - 255	67
	986	Switch off angle for thread trapper	B, C	0 - 255	206
	989	Thread trapper at beginning of seam 0 = no 1 = yes 2 = Thread clamp with sewing foot lift	B, C	0 - 2	0

▲ See Chapter 3 Specifications

\* Adjustment see Chapter 8.05 Basic position of the machine drive unit.

### 10.04.02 Parameter list for drive system MD-4-58-220-CE

Parameter	Description	Setting range	Set value
1	Speed max.	50 - 9999	▲
4	Speed for start backtackl	50 - 8000	1400
5	Speed for end backtack	50 - 8000	1400
46	Rotating direction of the motor	CW - CCW	CW
47	Selected machine class	0 - 101	62
61	Cutting speed 1	50 - 500	220
81	Needle position 6 (start cutting signal 2)	0 - 360°	40°
84	Needle position 5 (end cutting signal 1)	0 - 360°	90°
85	Needle position 9 (start thread tension release/start thread catcher)	0 - 360°	120°
87	Tension release after thread lever position at t.d.c.	0 - 1500ms	20ms
179	Needle position 2 (take-up lever raised)	0 - 359°	83°
181	Needle position 1 - needle lowered (192 = off)	0 - 255	250
210	Switch on angle for thread trapper	0 - 359°	20°
211	Switch off angle for thread trapper	0 - 359°	90°
236	Machine version 2 = 581 + 583	0 - 4	2

▲ See Chapter 3 Specifications

\* Adjustment see Chapter 8.05 Basic position of the machine drive unit.



## 11 Mounting the table top

### 11.01 Table top cutout

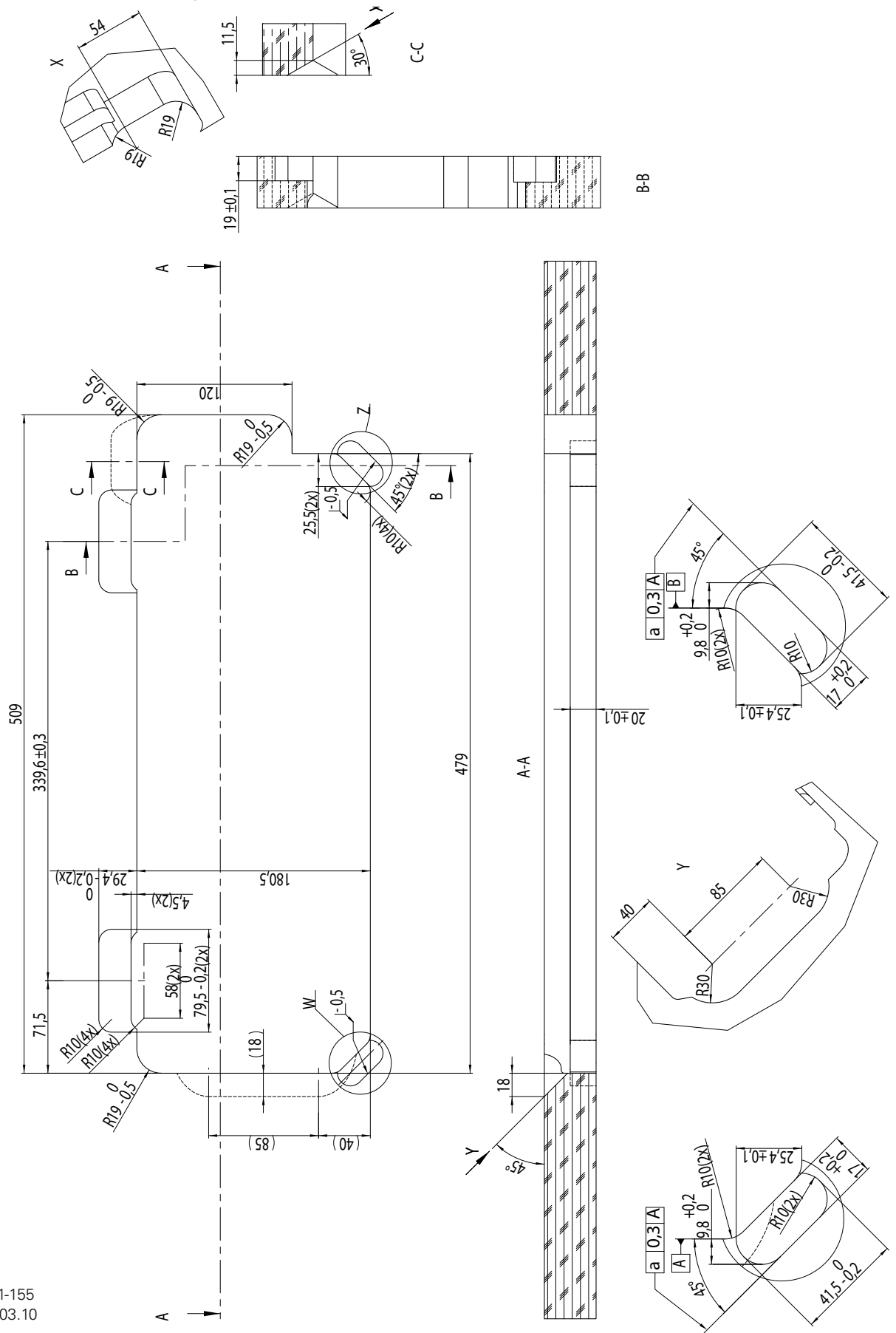

906-4001-155  
Vers. 24.03.10

# Mounting the table top

## 11.02 Mounting the table top (with drive system MD-4-58-220-CE)

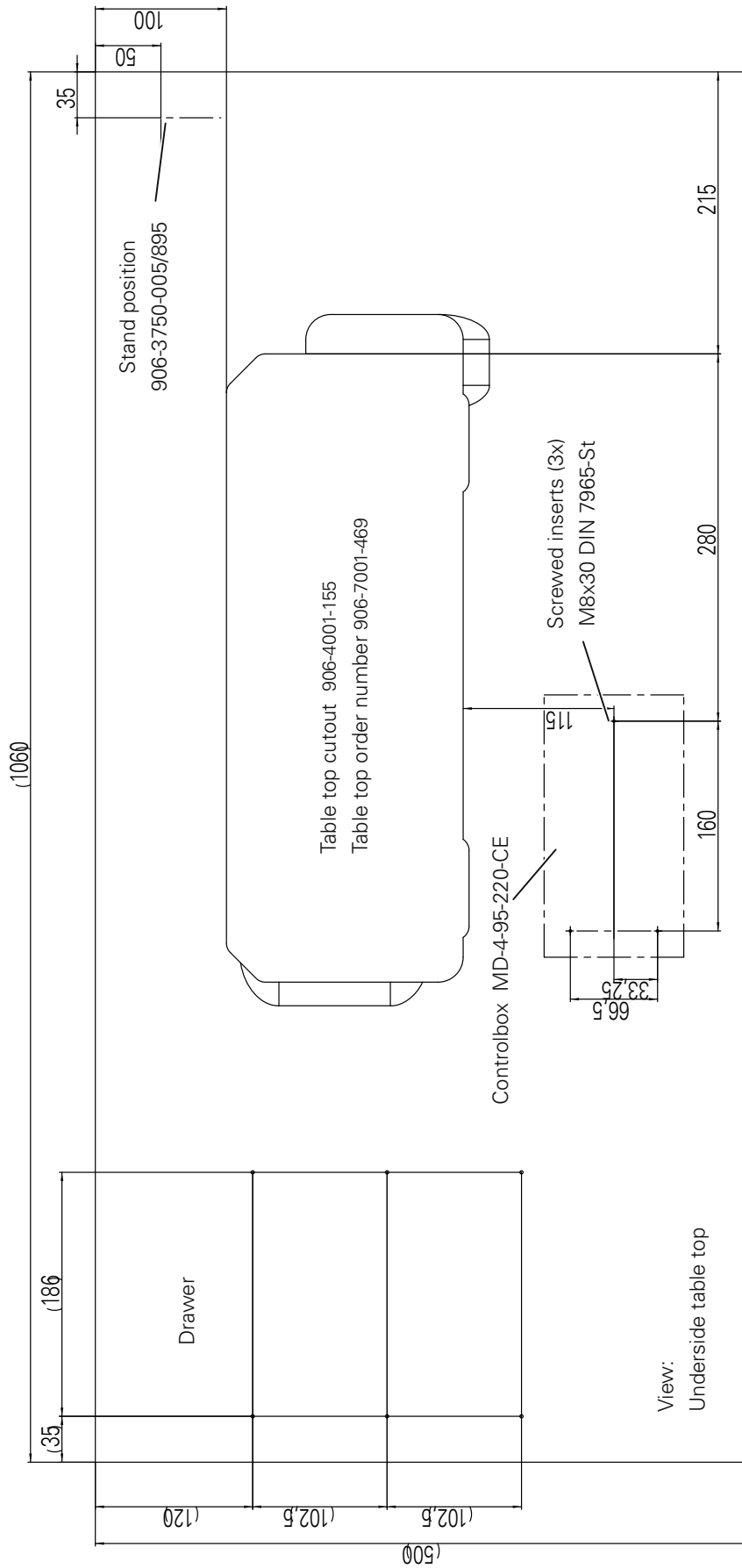

91-265 438-95  
Vers. 24.03.10

11.03 Mounting the table top (with PicoDrive and control unit P41 PD2)

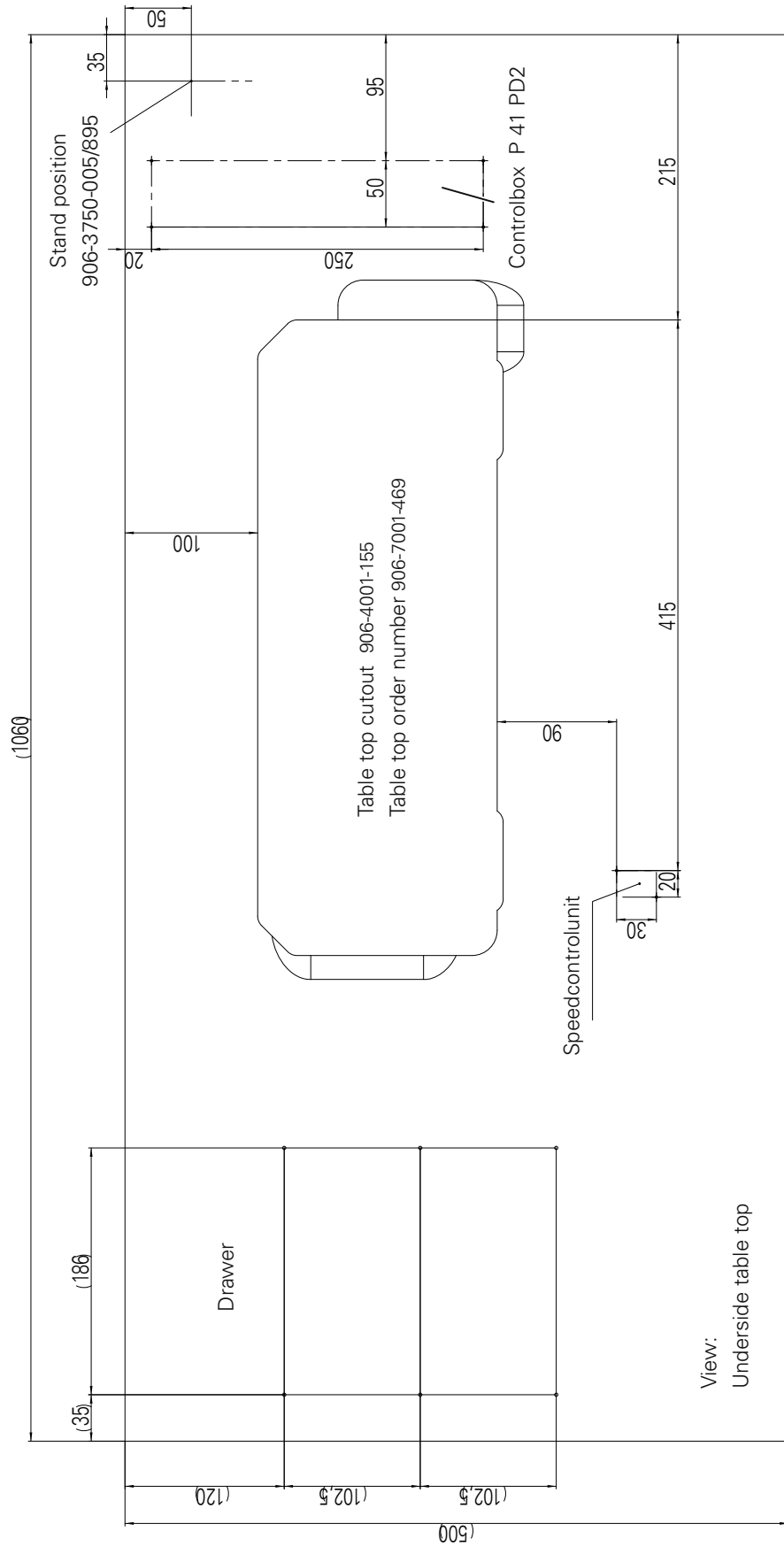

91-265 453-95  
Vers. 12.04.10

# Block diagram

## 12 Block diagram

12.01 PFAFF 581 + 583 with MD-4-58-220-CE

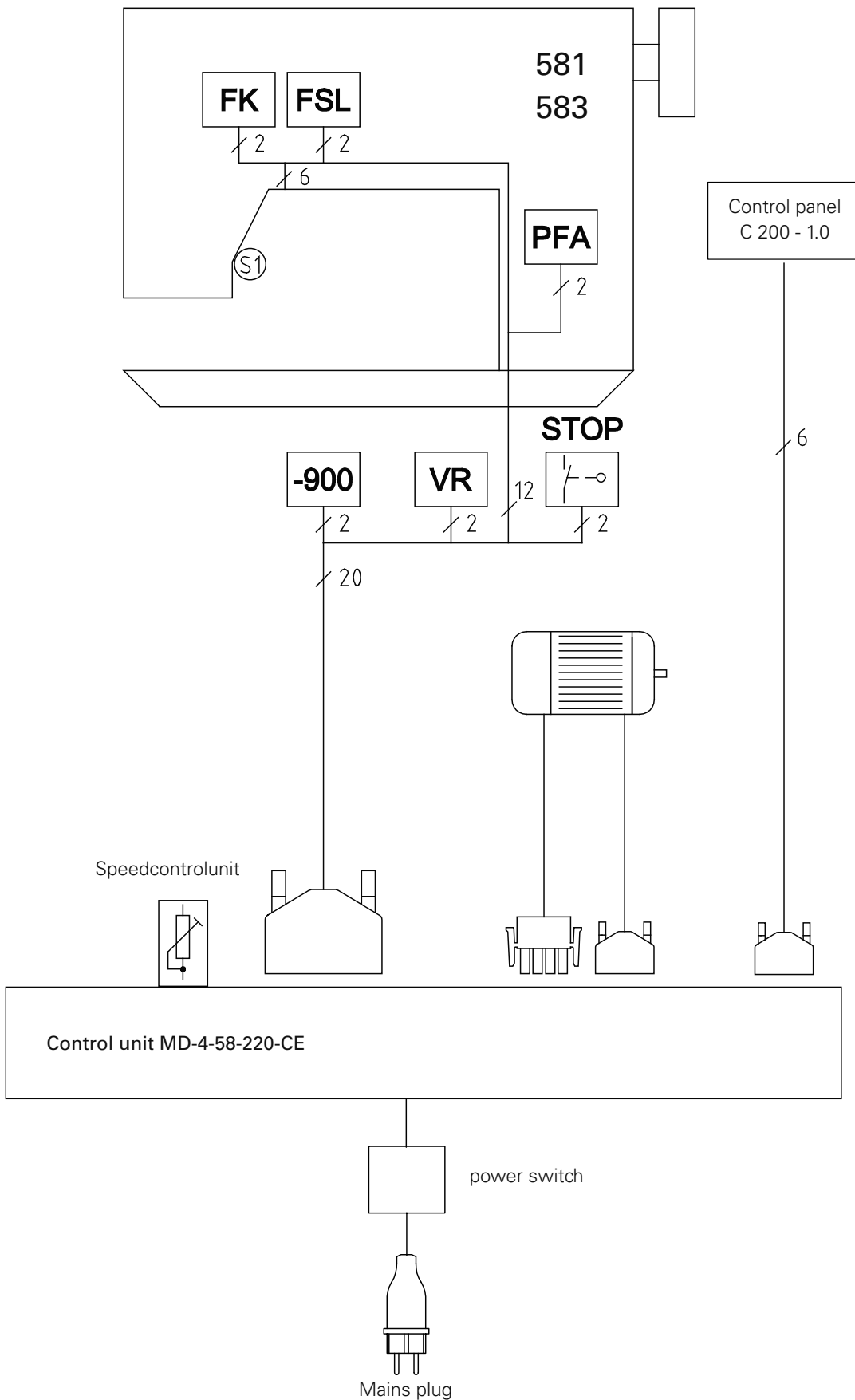

12.02 PFAFF 581 + 583 with PicoDrive and control unit P41 PD2

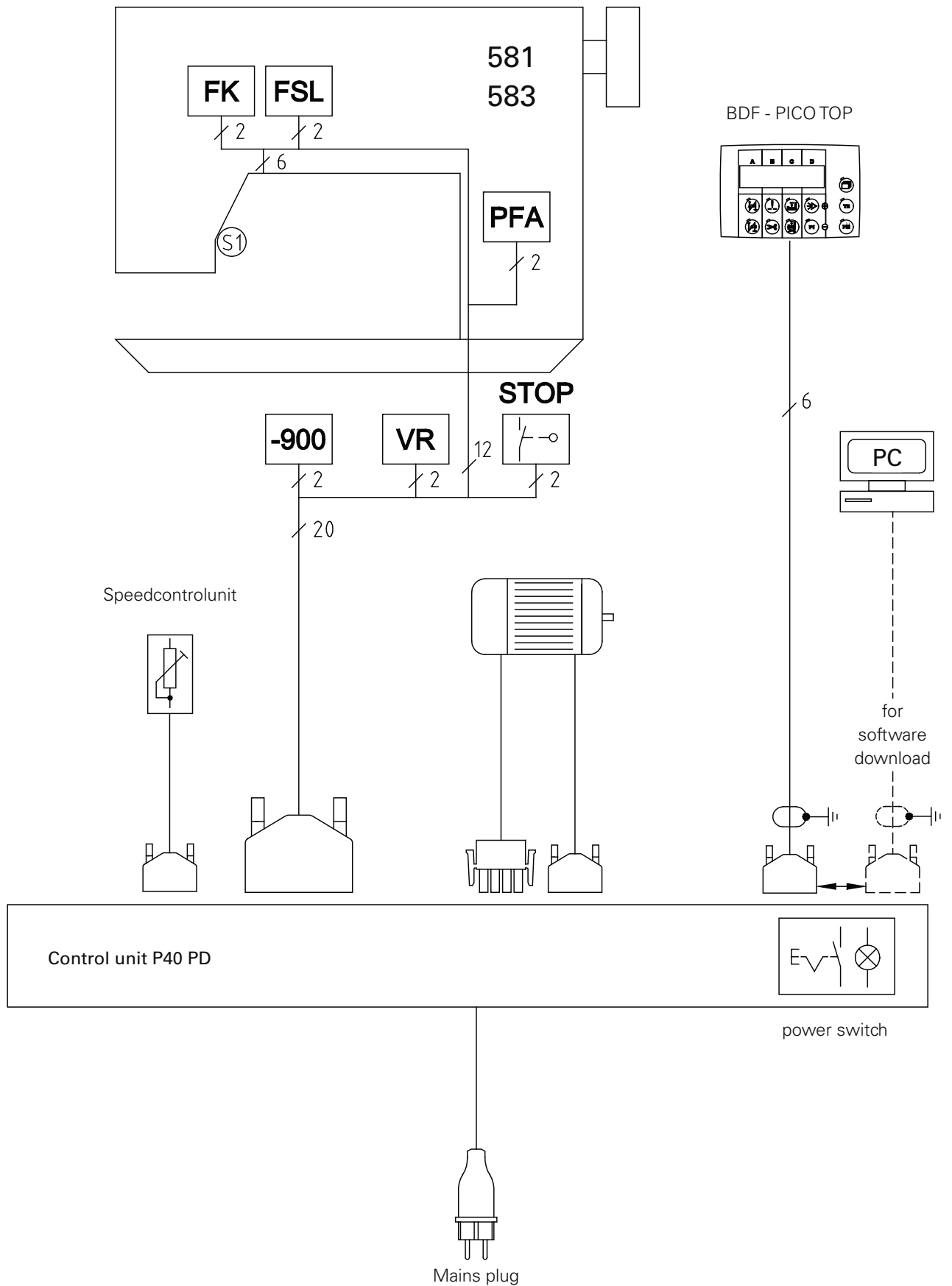

13

## Wearing parts

This is a list of the most important wearing parts.

A detailed parts list for the complete machine is included with the accessories.

In case of loss, the parts list can be downloaded from the internet address

**[www.pfaff-industrial.com/pfaff/de/service/downloads](http://www.pfaff-industrial.com/pfaff/de/service/downloads)** As an alternative to

the internet download the parts lists can also be ordered in book form under

part no. **296-12-19 139**.

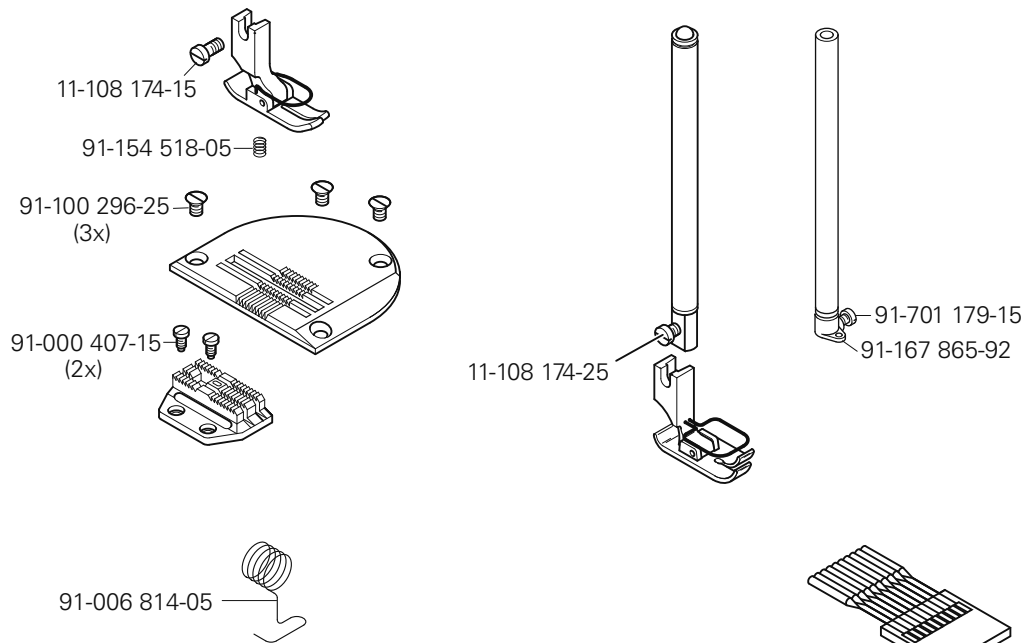

System 134

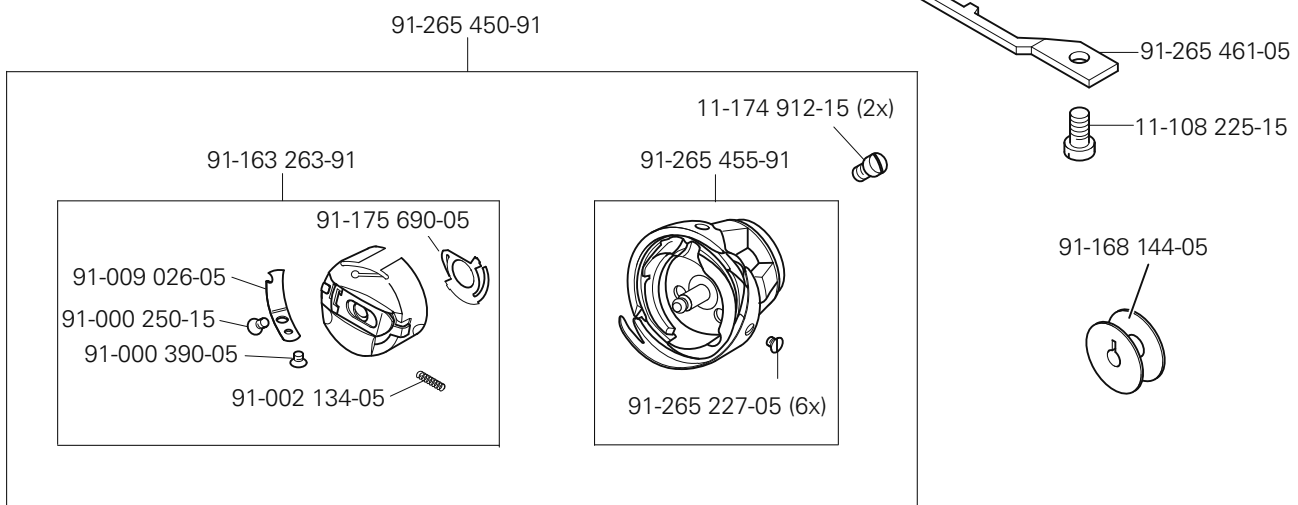

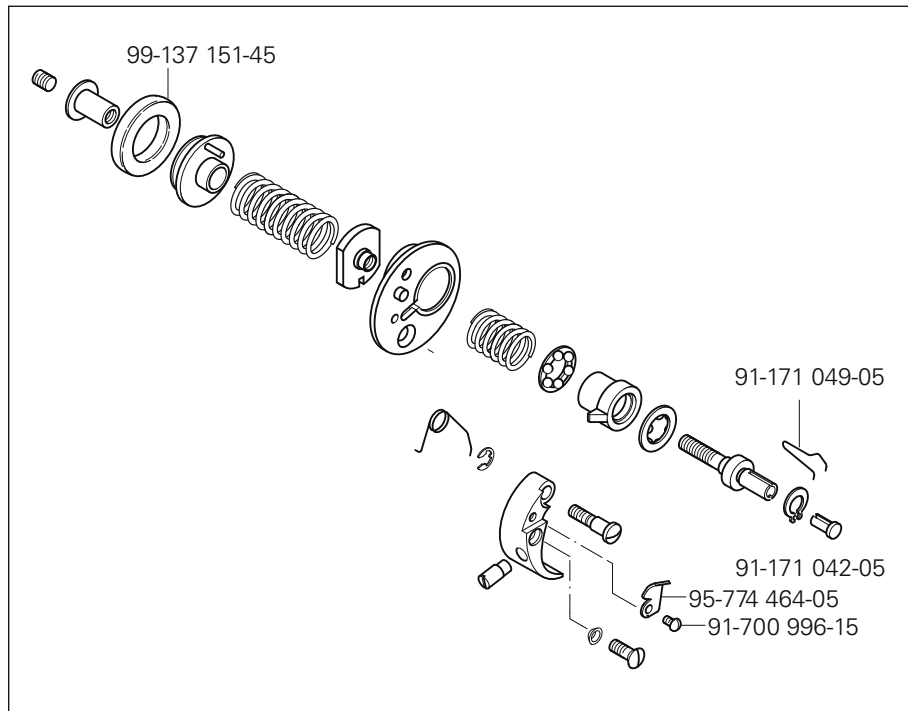

Unterklasse -900/..

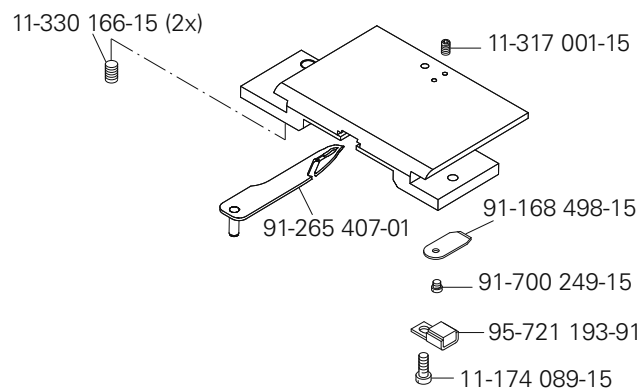



**Europäische Union**  
Wachstum durch Innovation – EFRE



## PFAFF Industriesysteme und Maschinen AG

Hans-Geiger-Str. 12 - IG Nord  
D-67661 Kaiserslautern

Telefon: +49-6301 3205 - 0  
Telefax: +49-6301 3205 - 1386  
E-mail: [info@pfaff-industrial.com](mailto:info@pfaff-industrial.com)