

3371-1/..

INSTRUCTION MANUAL

This instruction manual applies to machines from serial number **2 780 933** and software version **0335/022** onwards.



This Instruction Manual is valid for all models and subclasses listed in the chapter "Specifications".



The adjustment manual for the machines can be downloaded free of charge from the internet address

www.pfaff-industrial.com/pfaff/de/service/downloads.

As an alternative to the internet download the adjustment manual can also be ordered in book form under part no. **296-12-18 982/002**.

The reprinting, copying or translation of PFAFF Instruction Manuals, whether in whole or in part, is only permitted with our previous authorization and with written reference to the source.

**PFAFF Industriesysteme
und Maschinen AG**

Hans-Geiger-Str. 12 - IG Nord
D-67661 Kaiserslautern

	Contents	Chapter - Page
1	Safety	6
1.01	Directives	6
1.02	General notes on safety.....	6
1.03	Safety symbols	7
1.04	Important points for the user.....	7
1.05	Operating and specialist personnel.....	8
1.05.01	Operating personnel	8
1.05.02	Specialist personnel.....	8
1.06	Danger	9
2	Proper use.....	10
3	Specifications	11
4	Disposal of Machine	12
5	Transportation, packing and storage.....	13
5.01	Transportation to customer's premises	13
5.02	Transportation inside the customer's premises	13
5.03	Disposal of packing materials	13
5.04	Storage	13
6	Explanation of symbols.....	14
7	Control elements.....	15
7.01	Main switch	15
7.02	Pedal	15
7.03	Balance wheel.....	16
7.04	Control panel.....	16
7.04.01	Screen displays	17
7.04.02	Display symbols.....	17
7.04.03	Function keys	17
8	Installation and commissioning	19
8.01	Installation.....	19
8.01.01	Adjusting the table height.....	19
8.01.02	Removing the transit lock	20
8.01.03	Fitting the reel stand.....	20
8.01.04	Mounting the table top (for deliveries without stand).....	21
8.01.05	Table top drill hole plans.....	22
8.01.06	Connecting the plug-in connections and earth cable	24

Contents

	Contents	Chapter - Page
8.02	Commissioning the machine	24
8.03	Switching the machine on/off	24
9	Setting up	25
9.01	Inserting the needle	25
9.02	Threading the needle thread / adjusting the needle thread tension.....	26
9.03	Winding the bobbin thread	27
9.04	Removing / replacing the bobbin case	28
9.05	Threading the bobbin thread / adjusting the bobbin thread tension.....	28
9.06	Selecting a seam program	29
9.06.01	Selecting and changing the seam pattern.....	29
9.06.02	Selecting a program station.....	30
9.06.03	Selecting a sequence.....	30
9.07	Adjusting the size of the sewing area.....	31
9.08	Setting up the bobbin thread counter	32
9.09	Resetting the piece counter.....	32
9.10	Shifting the seam pattern.....	33
9.11	Inserting and removing the SD-memory card.....	34
10	Sewing	35
10.01	Operating cycle	35
10.02	Sewing in the "Direct program selection" mode	35
10.03	Sewing in the "Program stations" mode.....	35
10.04	Sewing in the "Sequences mode".....	36
10.04.01	Interrupting a sequence	36
10.05	Error messages.....	36
11	Input	37
11.01	Reserving program stations.....	37
11.02	Sequences	38
11.02.01	Entering sequences	38
11.02.02	Checking the sequence contents	38
11.02.03	Deleting sequences	39
11.02.04	Combining sequences	39
11.03	Parameter input	40
11.04	Access codes	41
11.04.01	Entering the access code	41
11.04.02	Changing the access code	41
11.04.03	Granting access rights	42
11.05	Summary of the seam patterns	43

		Chapter - Page
	Contents	
11.06	Program Management	46
11.06.01	Calling up the program management	46
11.06.02	Display of the data in the machine memory	47
11.06.03	Display of the data on the SD-memory card.....	48
11.06.04	Copying data onto the SD-memory card.....	49
11.06.05	Copying data into the machine memory.....	50
11.06.06	Deleting data in the machine memory.....	51
11.06.07	Deleting data from the SD-memory card.....	52
11.06.08	Formatting the SD-memory card	53
11.07	List of parameters.....	54
11.08	Error messages on the display.....	61
11.09	Sewing motor errors	63
11.10	OTE-errors.....	63
12	Care and maintenance.....	64
12.01	Maintenance intervals.....	64
12.02	Cleaning the machine	64
12.03	Cleaning the hook compartment	65
12.04	Oiling the needle head parts	65
12.05	Oiling the hook.....	66
12.06	Oiling the bearing points in the arm.....	67
12.07	Oil disposal	67
12.08	Cleaning the blower air filter	68
13	Wearing parts	69

1 Safety

1.01 Directives

This machine is constructed in accordance with the European regulations contained in the conformity and manufacturer's declarations.

In addition to this Instruction Manual, also observe all generally accepted, statutory and other regulations and legal requirements and all valid environmental protection regulations! The regionally valid regulations of the social insurance society for occupational accidents or other supervisory organizations are to be strictly adhered to!

1.02 General notes on safety

- This machine may only be operated by adequately trained operators and only after having completely read and understood the Instruction Manual!
- All Notes on Safety and Instruction Manuals of the motor manufacturer are to be read before operating the machine!
- The danger and safety instructions on the machine itself are to be followed!
- This machine may only be used for the purpose for which it is intended and may not be operated without its safety devices. All safety regulations relevant to its operation are to be adhered to.
- When exchanging sewing tools (e.g. needle, needle plate and bobbin), when threading the machine, when leaving the machine unattended and during maintenance work, the machine is to be separated from the power supply by switching off the On/Off switch or by removing the plug from the mains!
- Everyday maintenance work is only to be carried out by appropriately trained personnel!
- Repairs and special maintenance work may only be carried out by qualified service staff or appropriately trained personnel!
- Work on electrical equipment may only be carried out by appropriately trained personnel!
- Work is not permitted on parts and equipment which are connected to the power supply! The only exceptions to this rule are found in the regulations EN 50110.
- Modifications and alterations to the machine may only be carried out under observance of all the relevant safety regulations!
- Only spare parts which have been approved by us are to be used for repairs! We expressly point out that any replacement parts or accessories which are not supplied by us have not been tested and approved by us. The installation and/or use of any such products can lead to negative changes in the structural characteristics of the machine. We are not liable for any damage which may be caused by non-original parts.

1.03 Safety symbols



Danger!
Points to be observed..



Danger of injury for operating and specialist personnel!



Caution

Do not operate without finger guard and safety devices.
Before threading, changing bobbin and needle, cleaning etc. **switch off main switch.**

1.04 Important points for the user

- This Instruction Manual is an integral part of the machine and must be available to the operating personnel at all times.
- The Instruction Manual must be read before operating the machine for the first time.
- The operating and specialist personnel is to be instructed as to the safety equipment of the machine and regarding safe work methods.
- It is the duty of the user to only operate the machine in perfect running order.
- It is the obligation of the user to ensure that none of the safety mechanisms are removed or deactivated.
- It is the obligation of the user to ensure that only authorized persons operate and work on the machine.

Further information can be obtained from your PFAFF agent.

1.05 Operating and specialist personnel

1.05.01 Operating personnel

Operating personnel are persons responsible for the equipping, operating and cleaning of the machine as well as for taking care of problems arising in the sewing area.

The operating personnel is required to observe the following points and must:

- always observe the Notes on Safety in the Instruction Manual!
- never use any working methods which could adversely affect the safety of the machine!
- not wear loose-fitting clothing or jewelery such as chains or rings!
- also ensure that only authorized persons have access to the potentially dangerous area around the machine!
- always immediately report to the person responsible any changes in the machine which may limit its safety!

1.05.02 Specialist personnel

Specialist personnel are persons with a specialist education in the fields of electrics, electronics and mechanics. They are responsible for the lubrication, maintenance, repair and adjustment of the machine.

The specialist personnel is obliged to observe the following points and must:

- always observe the Notes on Safety in the Instruction Manual!
- switch off the On/Off switch before carrying out adjustments or repairs, and ensure that it cannot be switched on again unintentionally!
- wait until the luminous diode on the control box is no longer blinking or on before beginning adjustment or repair work.
- never work on parts which are still connected to the power supply! Exceptions are explained in the regulations EN 50110.
- replace the protective coverings and close the electrical control box after all repairs or maintenance work!

1.06

Danger



A working area of **1 meter** is to be kept free both in front of and behind the machine while it is in operation so that it is always easily accessible.



Never reach into the sewing area while sewing!
Danger of injury by the needle!



Never leave objects on the table while adjusting the machine settings!
Objects can become trapped or be slung away! Danger of injury!

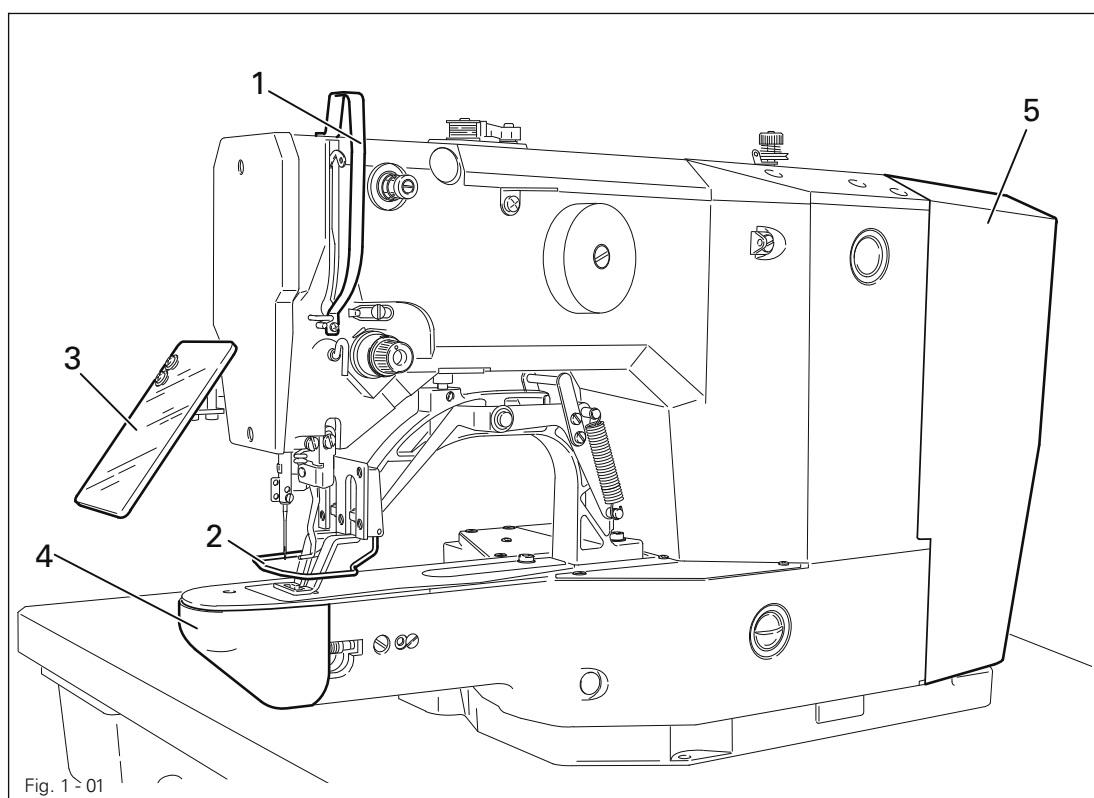

Do not operate the machine without its take-up-lever guard **1!**
Danger of injury due to the motion of the take-up lever!



Do not operate the machine without finger deflector **2!**
Danger of injury by the needle!



Do not operate the machine without eye shield **3!**
Danger of injury from flying needle fragments!



Only operate the machine with cover **4** closed!
Danger of injury from rotating hook!



Do not operate the machine without cover **5!**
Danger of injury from moving parts!

2

Proper use

The Pfaff 3371-1/.. is an automatic sewing machine for sewing lockstitch bartacks and short seams in the sewing industry..



Any and all uses of this machine which have not been approved of by the manufacturer are considered to be inappropriate! The manufacturer cannot be held liable for any damage caused by the inappropriate use of the machine! The appropriate use of the machine includes the observance of all operational, adjustment, maintenance and repair measures required by the manufacturer!

3 Specifications ▲

Max. sewing speed: 2700 spm⁻¹
Feed type: intermittent
Stitch length: 0.1 – 10.0 mm
Stitch type: 301 (lockstitch)

Needle size in 1/100 mm:
for fine materials: 70 - 100
for medium-weight materials: 100 - 120
for medium-heavy materials: 120 - 140
Needle system: 134 (DPx5)
Needle bar stroke: 41 mm

Fabric clearance: max. 17 mm
Max. size of sewing area: 40 x 20 mm

Power supply: 230 V ± 10%, 50/60 Hz, single phase
Power consumption: 0.55 kVA
Electrical power rating: 1,2 kVA
Fuse protection: 1x 16 A, inert

Noise data:
Noise emission level at workplace
with a sewing cycle of 1 sec. on and 2 sec. off: $L_{pA} = 74$ dB(A) ■
(Noise measurement in accordance with DIN 45 635-48-B-1, ISO 11204, ISO 3744, ISO 4871)

Sewing head dimensions:
Length: approx. 700 mm
Width: approx. 220 mm
Height: approx. 380 mm

Dimensions of standard base:
Length: approx. 1060 mm
Width: approx. 600 mm
Height: approx. 820 mm

Weights
Sewing head: approx. 42 kilos
Base incl. control box: approx. 45 kilos

▲ Subject to alterations

■ $K_{pA} = 2,5$ dB

4

Disposal of Machine

- Proper disposal of the machine is the responsibility of the customer.
- The materials used for the machine are steel, aluminium, brass and various plastic materials. The electrical equipment comprises plastic materials and copper.
- The machine is to be disposed of according to the locally valid pollution control regulations; if necessary, a specialist is to be commissioned.



Care must be taken that parts soiled with lubricants are disposed of separately according to the locally valid pollution control regulations!

5 Transportation, packing and storage

5.01 Transportation to customer's premises

The machines are delivered completely packed.

5.02 Transportation inside the customer's premises

The manufacturer cannot be made liable for transportation inside the customer's premises nor to other operating locations. It must be ensured that the machines are only transported in an upright position.

5.03 Disposal of packing materials

The packing materials of this machine comprise paper, cardboard and VCE fibre. Proper disposal of the packing material is the responsibility of the customer.

5.04 Storage

If the machine is not in use, it can be stored as it is for a period of up to six months, but it should be protected against dust and moisture.

If the machine is stored for longer periods, the individual parts, especially the surfaces of moving parts, must be protected against corrosion, e.g. by a film of oil.

6 Explanation of symbols

In this instruction manual, work to be carried out or important information is accentuated by symbols. These symbols have the following meanings:



Note, information



Cleaning, care



Lubrication

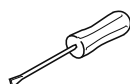

Maintenance, repairs, adjustment, service work
(only to be carried out by technical staff)

7 Control elements

7.01 Main switch

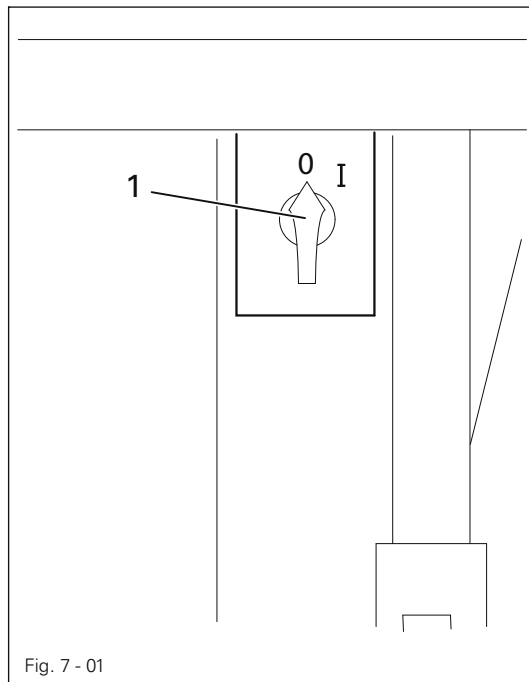

Fig. 7 - 01

- Switch the machine on or off by turning main switch 1.

7.02 Pedal

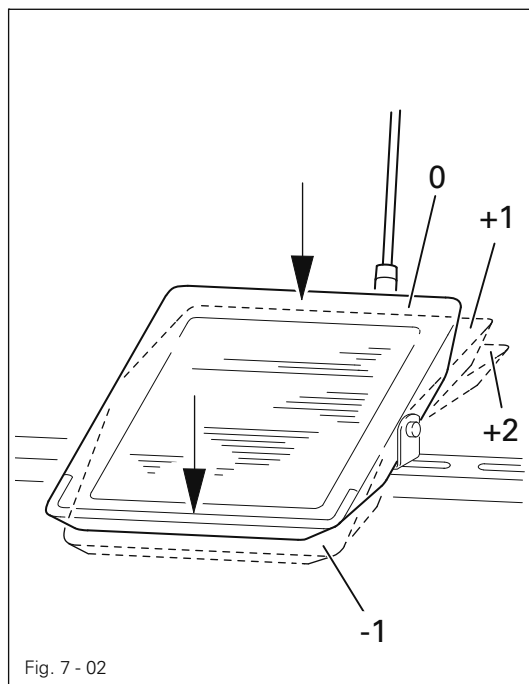

Fig. 7 - 02

- The pedal is used to lower and raise the work clamp, and to start the sewing-program.

- 1 = sewing interruption
- 0 = neutral position
- +1 = lower work clamp
- +2 = sewing

7.03 Balance wheel

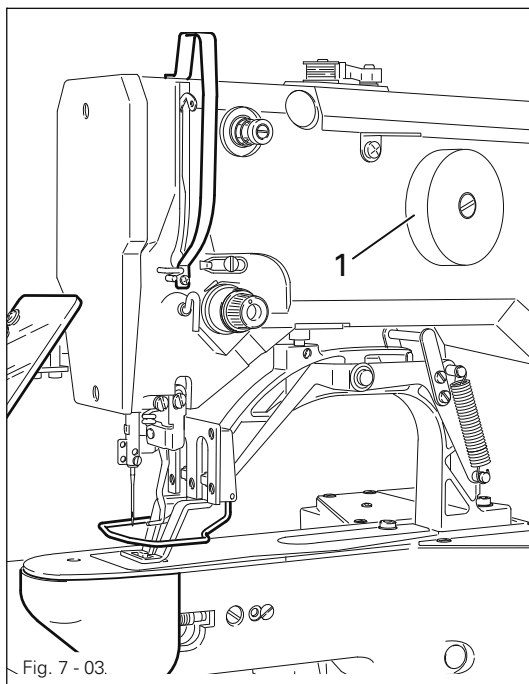

Fig. 7 - 03.

- By pressing and holding down balance wheel 1, it is possible to adjust the needle bar manually.

7.04 Control panel

The control panel is used to select seam programs, call up machine functions, change parameters, control the different operating modes, as well as for reading error signals and service settings.

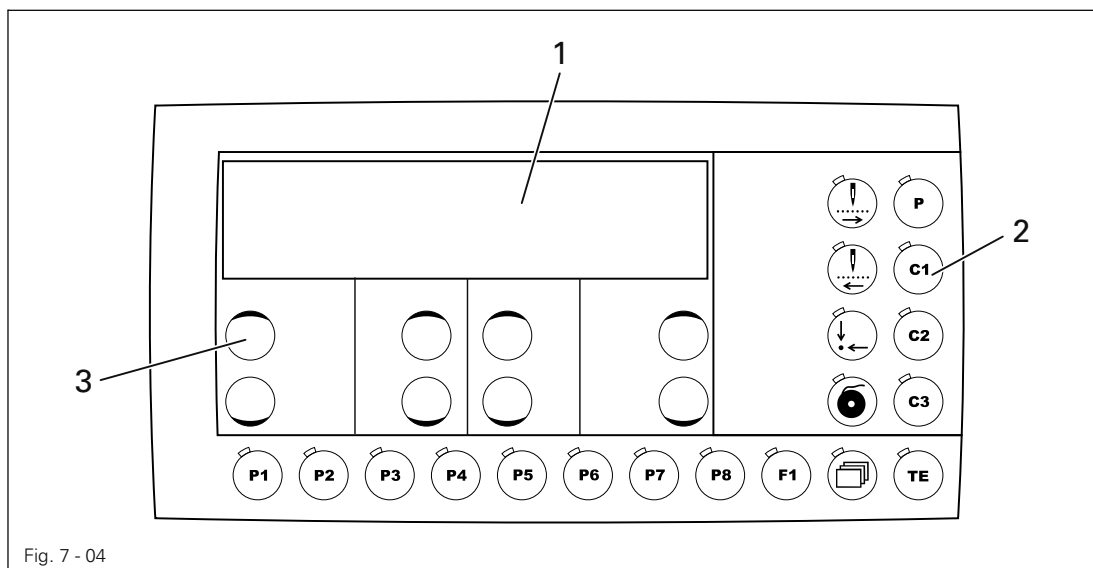

Fig. 7 - 04

The control panel consists of display screen 1 with the function keys described below. The display 1 consists of a two-row alphanumerical LCD display with 16 symbols per row. The function keys 2 are located below and to the right of the display screen. The status of the function keys and the machine operating modes are shown with LEDs in the corresponding keys. Every time the function keys 2 are operated, a key tone sounds as confirmation of the







input. If the input required is invalid, e.g. because the max. permissible value for the parameter input has been reached, a double tone is audible. An SD-card reader for data transfer is integrated.

7.04.01 Screen displays

Depending on the operating mode, on the screen **1** information is shown about the machine status, program selection, sequence program progress, input parameters, as well as error signals (also see Chapter **11 Input**).

- Depending on the operating mode, relevant data is displayed in combination with the appropriate symbol or text, and can be altered directly.
- When the parameters are entered, the number of the parameter selected is shown with the corresponding parameter value, see Chapter **11.03** Parameter input.
- If faults occur in the sewing operation, a corresponding error signal appears in the display, see Chapter **11.08 Error messages on the display**.

7.04.02 Display symbols

	Program number
	Speed
X	Size factor X-direction (crosswise) in %
Y	Size factor Y-direction (lengthwise) in %
	Bobbin thread counter / piece counter
	Enter
	Machine memory
	SD-memory card

7.04.03 Function keys

The functions keys described below are used essentially to switch machine functions on and off. When the function is switched on, the **diode in the key is illuminated**.

If a corresponding value has to be fixed for the activated function, this can be carried out with the corresponding **+/- keys 3**.



By pressing and holding the corresponding **+/- key**, firstly the numerical value displayed above it is altered slowly. If the **+/- key** is pressed longer, the numerical value changes more



quickly. The respective **+/- keys** shown opposite are described below.



Menü

This function is used in the respective operating mode to scroll within the existing menus.



Wind

The bobbin thread winding function is called up, see Chapter 9.03 **Winding the bobbin thread**.



Basic position

Work clamp and needle are positioned in the basic position and , if necessary, the thread trimming function is activated.



Tacting backwards

Each time the key is pressed, the selected seam program is sewn stitch by stitch in reverse, and the coordinates for each stitch are shown on the control panel.



Tacting forwards

Each time the key is pressed, the selected seam program is sewn forwards stitch by stitch, and the coordinates for each stitch are shown on the control panel.



to



Program stations

The function keys P1 to P8 are used to enter and select seam programs, see Chapter 9.06.02 **Selecting the program station**.



Direct program selection

This function is used to select a seam pattern. After selection, speed and size can be altered, see Chapter 9.06.01 **Selecting and altering the seam pattern**.



to



Sequences

The function keys C1 to C3 are used to enter and select sequences, see Chapter 9.06.03 **Selecting a sequence**.



TE

In the sewing mode, this key is used to change to the input mode. In the input mode this key is used to acknowledge the input of program stations and sequences, and to change into the sewing mode.

8 Installation and commissioning



The machine must only be installed and commissioned by qualified personnel!
All relevant safety regulations must be strictly adhered to!
If the machine is delivered without a table, be sure to use a stand and table top that can hold the weight of the machine with its motor.
It is very important to ensure that the stand of the machine is firm and steady, also during sewing.

8.01 Installation

The site where the machine is installed must be provided with suitable connections for the electric current, see Chapter 3 **Specifications**.

It must also be ensured that the standing surface of the machine site is firm and horizontal, and that sufficient lighting is provided.



For packing and transportation reasons the table top is in the lowered position.
The table height is adjusted as described below.



If the machine is delivered with stand, the transit lock must be removed before commissioning, see Chapter 8.01.02 **Removing the transit lock**.

8.01.01 Adjusting the table height

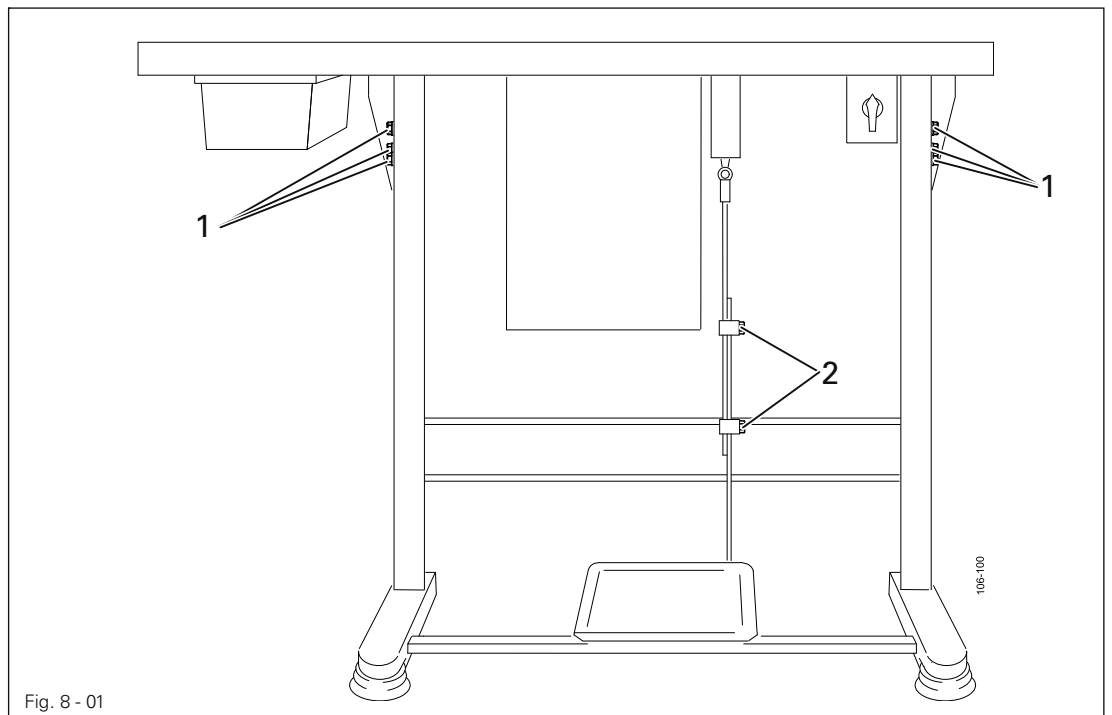

- Loosen screws 1 and 2 and set the table height as required.
- Firmly tighten screw 1.
- Set the required pedal position and tighten screw 2.

Installation and commissioning

8.01.02 Removing the transit lock

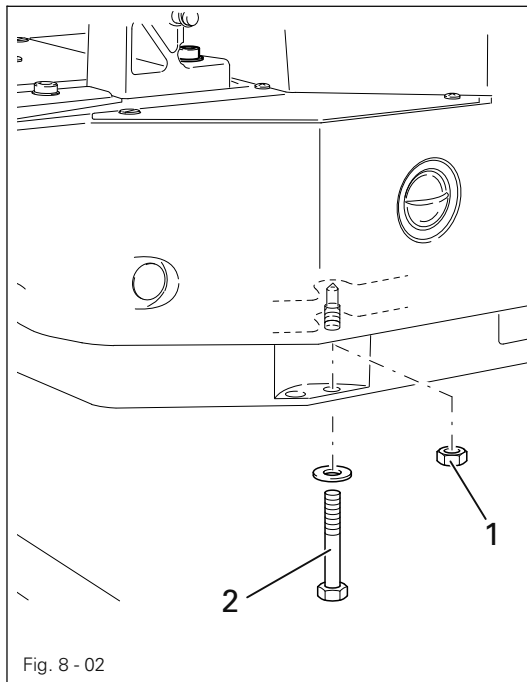

- Loosen nut 1.
- Remove screw 2.

8.01.03 Fitting the reel stand

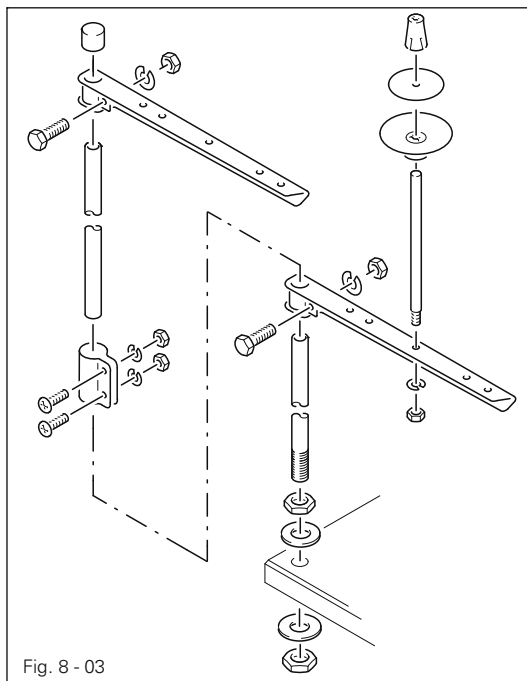

- Fit the reel stand as shown in Fig. 8 - 03.
- Afterwards insert the stand in the hole in the table top and secure it with nuts provided.

8.01.04 Mounting the table top (for deliveries without stand)

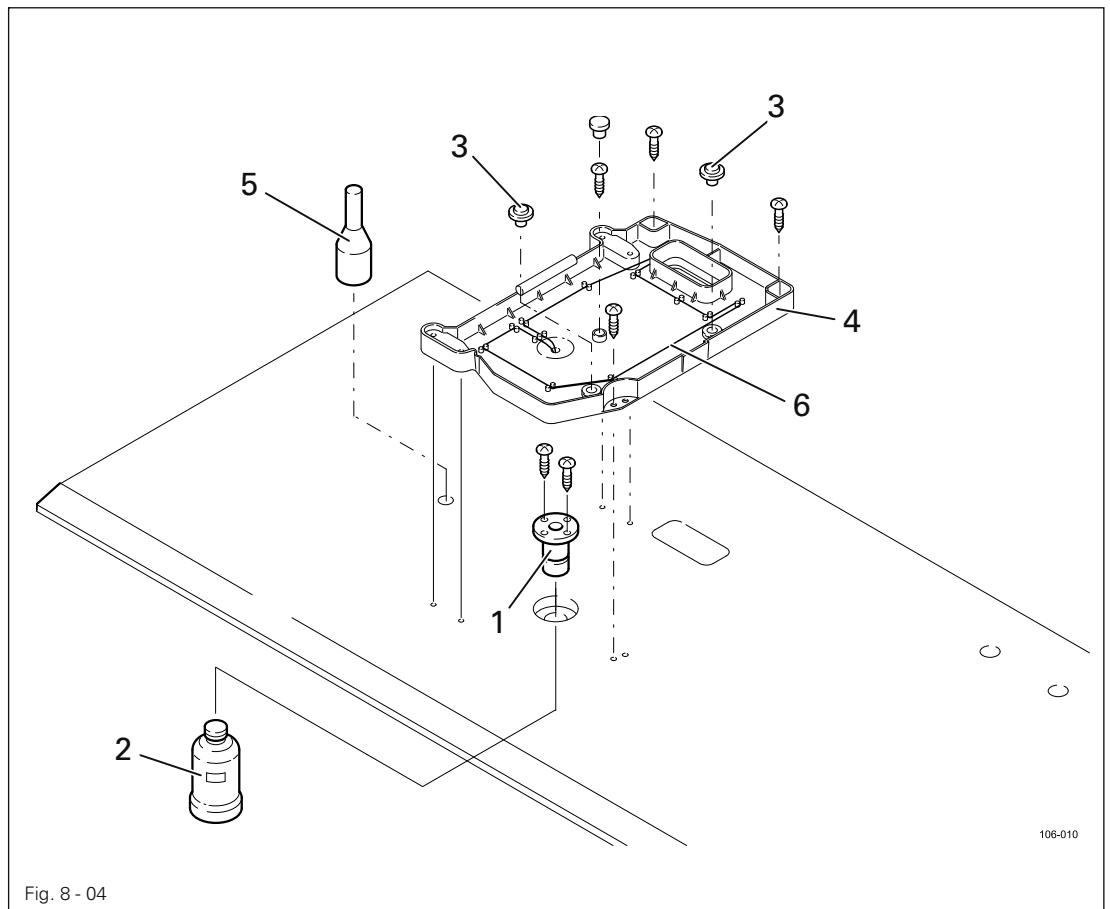

- Drill holes in the table top as shown in the drawing, see Chapter 8.01.05 Table top drill hole plans.
- Screw on the oil outlet 1.
- Screw the oil tank 2 to oil outlet 1.
- Set the rubber pads 3 in the fastening holes of the oil pan 4 and screw oil pan 4 to the table top.
- Set support 5 in the appropriate hole.
- Place wick 6 in the holders of oil pan 4.

Installation and commissioning

8.01.05 Table top drill hole plans

Top view

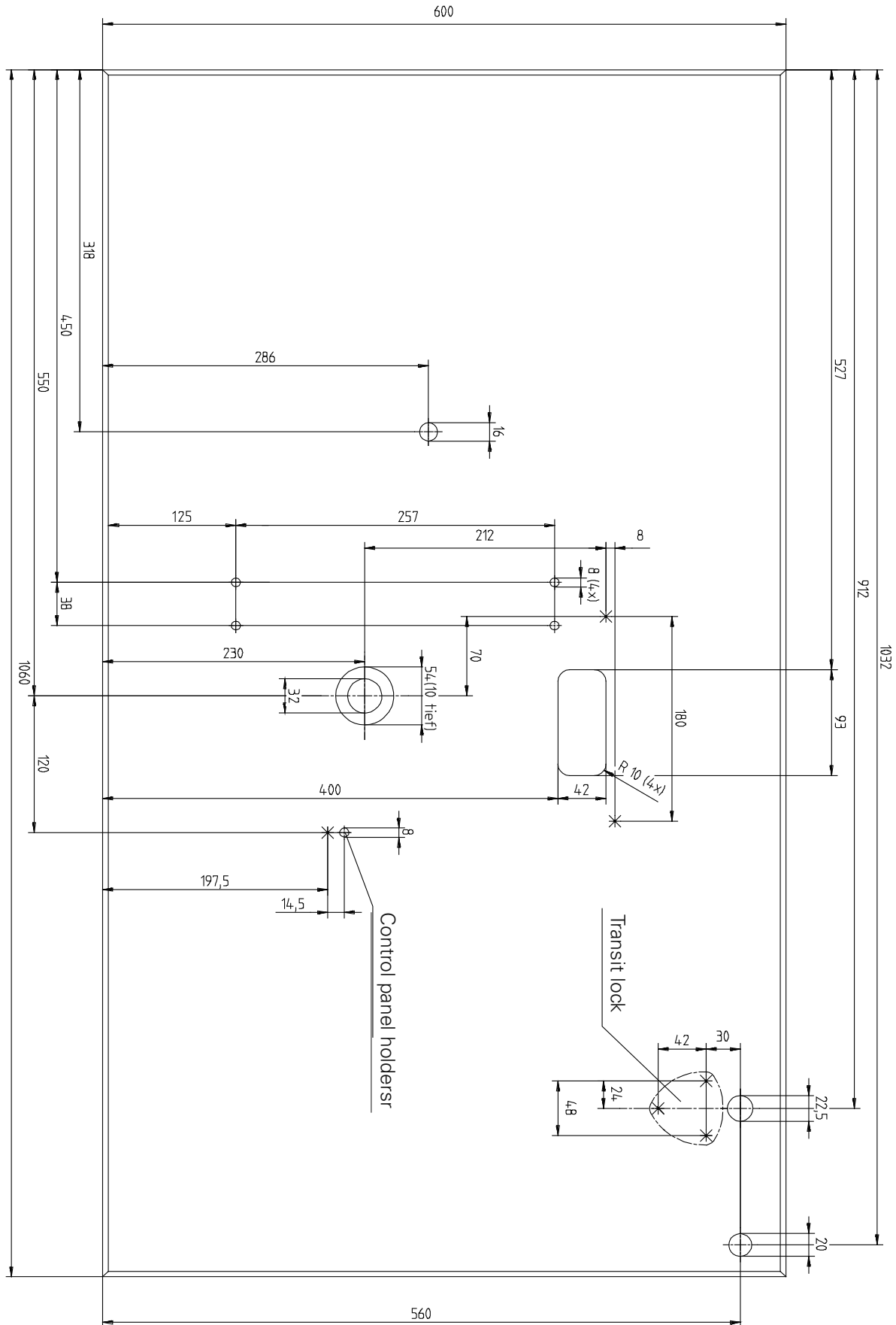

Bottom view

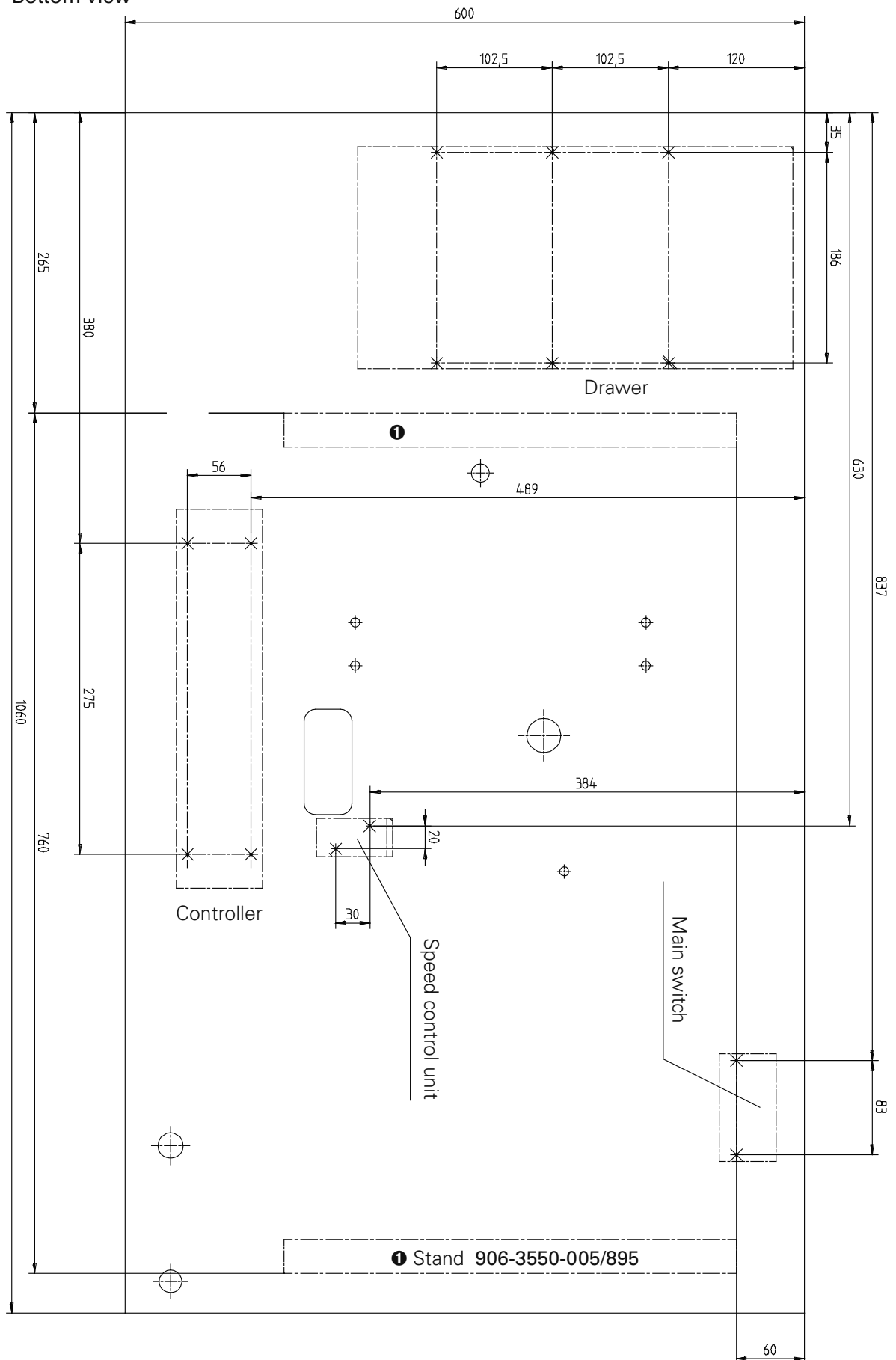

8.01.06 Connecting the plug-in connections and earth cable

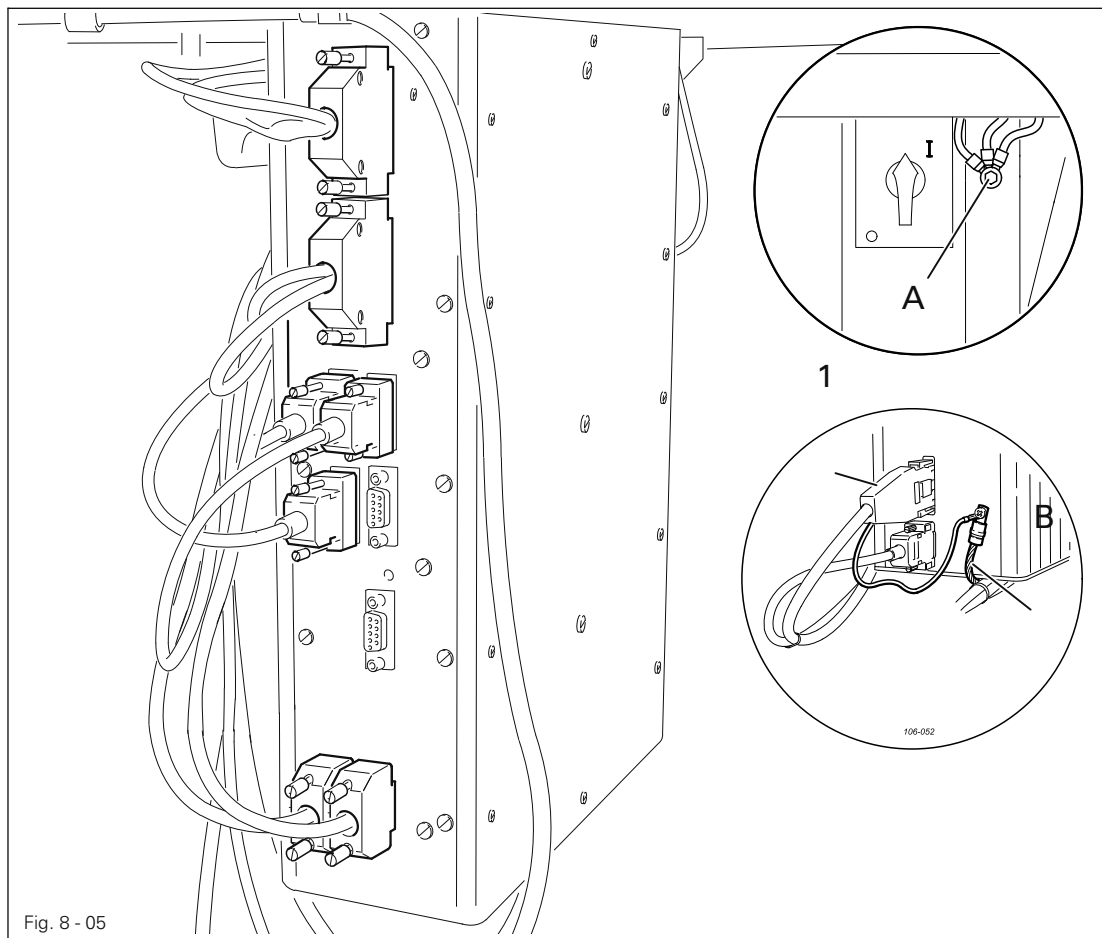

- Connect all plugs as labelled in the control box.
- Screw the earth cable from the machine and the main switch to earth point A.
- Connect earth point A and earth point B with an earth cable.
- Screw the earth cable of plug 1 to earth point B.

8.02 Commissioning the machine

- Clean the machine thoroughly.
- Check the oil level, see Chapter 12 **Care and Maintenance**.
- Check the machine, especially the electric wires, for any damage.
- Have specialists check, whether the machine's motor can be used with the existing mains voltage.

8.03 Switching the machine on/off

- Switching the machine on/off, see Chapter 7.01 **Main switch**.

9

Setting up



All instructions and regulations in this instruction manual must be observed. Special attention must be given to all safety regulations!



All setting-up work must only be done by personnel with the necessary training. For all setting-up work the machine must be isolated from its power supply by turning off the on/off switch or removing the machine plug from the electric power socket!

9.01

Inserting the needle

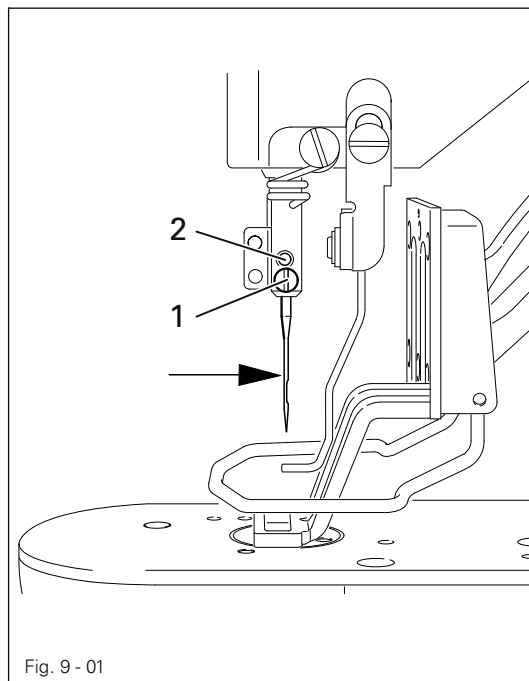

Switch off the machine!
Danger of injury if the machine is started accidentally!



Only use needles from the system intended for the machine, see Chapter 3 Specifications.

- Loosen screw 1.
- Insert the needle as far as possible. The long needle groove (see arrow) must be facing forwards.
- Tighten screw 1.



Through hole 2 it is possible to check whether the needle has been inserting as far as possible. Broken needles can be removed by inserted suitable tools in hole 2.

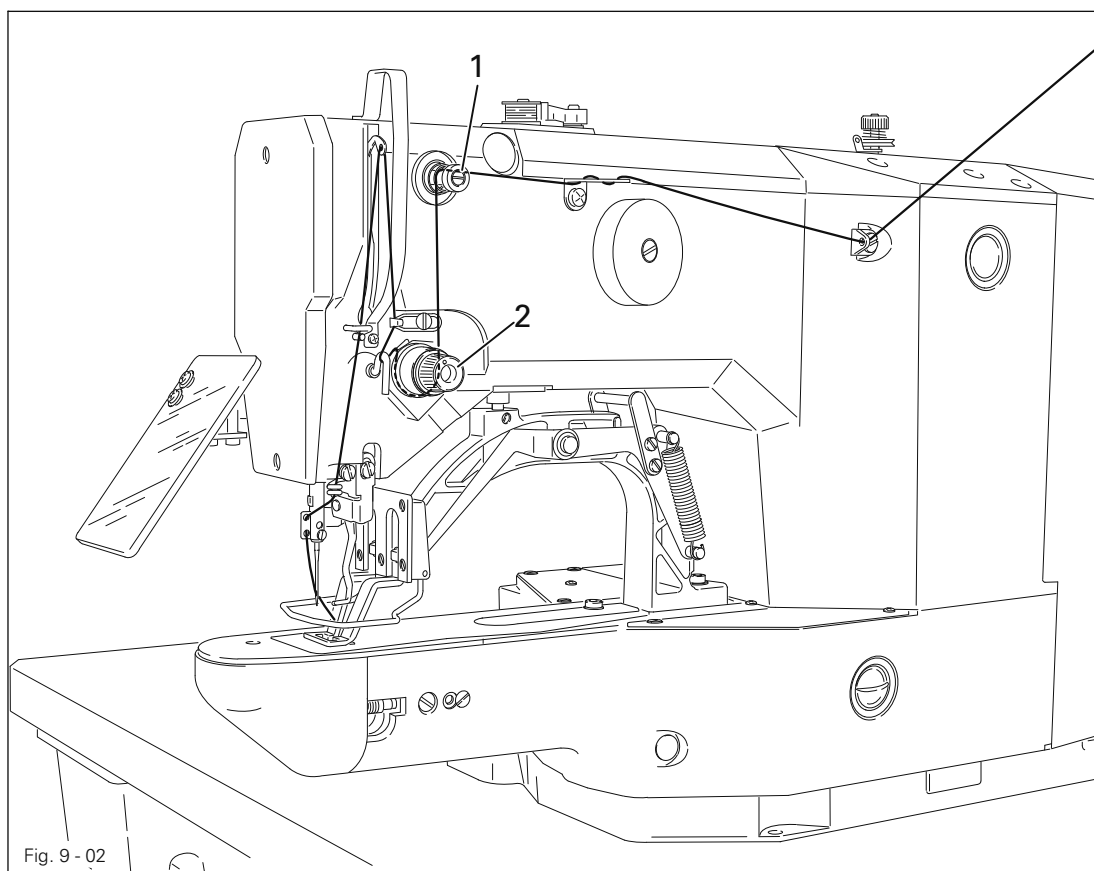

Switch off the machine!

Danger of injury if the machine is started accidentally!

- Thread the needle thread as shown in Fig. 9-02.
- Adjust the needle thread tension by turning milled nuts 1 and 2.

9.03 Winding the bobbin thread

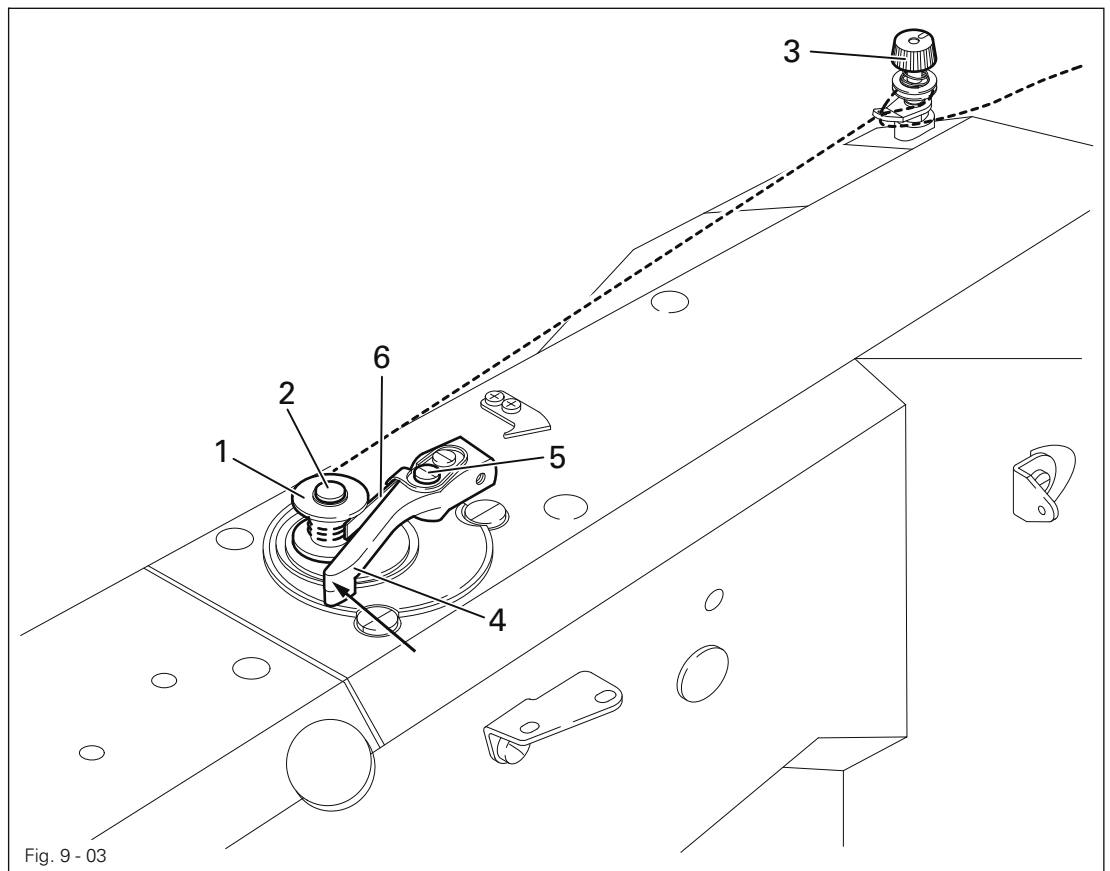

Fig. 9 - 03

- Place the empty bobbin 1 on the bobbin winder spindle 2.
- Thread the thread as shown in Fig. 9-03 and wind it round bobbin 1 a few times in the anti-clockwise direction.
- Set the preliminary thread tension by turning milled screw 3.
- Press lever 4 in the direction of the arrow until it clicks into place.



The bobbin is filled during sewing.



- Winding is also possible as follows:
- Switch on the machine and press the **key for winding**.
- Remove the thread from the needle and take-up lever.
- Operate the pedal to carry out winding, the bobbin winder stops automatically as soon as the bobbin is adequately full.



- Press the **key for winding**, the machine stops.
- Thread the machine again.

Adjusting the amount of thread on the bobbin

- Loosen screw 5.
- Set stop 6 so that the bobbin winder switches off automatically when the thread is still ca. 1 mm from the edge of the bobbin.
- Tighten screw 5.

9.04 Removing / replacing the bobbin case

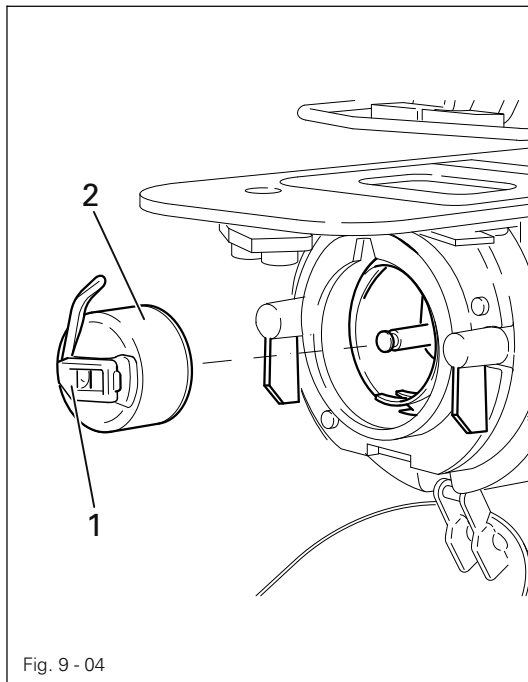

Switch off the machine.
Danger of injury if the machine starts accidentally!

Removing the bobbin case

- Open the hook cover
- Pull out latch 1
- Remove bobbin case 2

Replacing the bobbin case

- Push bobbin case 2 into the bobbin case base until you feel it click into place
- Close the hook cover.

9.05 Threading the bobbin thread / adjusting the bobbin thread tension

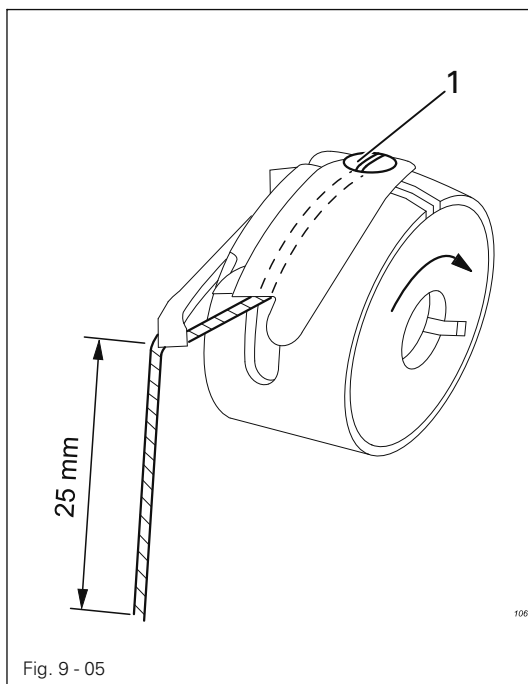

- Place the bobbin into the bobbin case, so that this turns in the direction shown by the arrow when the thread is pulled.
- Insert the thread as shown in Fig. 9-05.
- Set the thread tension by turning screw 1.

9.06 Selecting a seam program

After the machine has been switched on, it is in its basic position and offers various possibilities for selecting seam programs.





- Direct selection of the seam pattern and its individual adaptation by changing the speed and size factors.
- Selection of the seam program via a program station. For this purpose a seam pattern with its respective speed and corresponding size factors must have been stored previously.
- With the selection of a sequence several seam programs are sewn after each other. For this purpose a sequence must have been compiled beforehand from individual seam programs (program stations).

9.06.01 Selecting and changing the seam pattern.

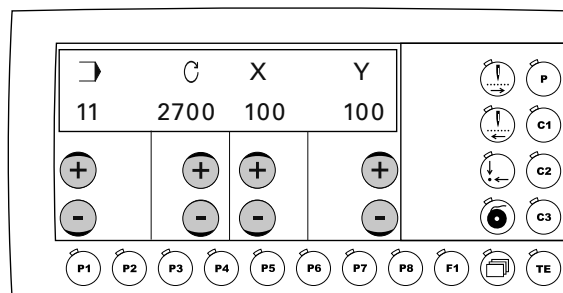

- With the machine in the basic position, select the direct seam pattern.



-  ● With the corresponding +/- key select the desired seam pattern, e.g. 11. The seam patterns are stored in the machine under program numbers, see Chapter 11.05 Summary of the seam patterns.
-  ● Select the desired speed with the corresponding +/- key.
-  ● Enter the desired size factor (in %) (X-direction) with the corresponding +/- key.
-  ● Enter the desired size factor (in %) (Y-direction) with the corresponding +/- key.



- To conclude the input, press the TE key or operate the pedal forwards (machine changes to the sewing mode).



The enlargement of the seam pattern is limited by the size of the machine's sewing area.



The altered speed and size factors entered are not stored when the machine changes to another seam program. If you wish to store these values, a station key must be reserved with the corresponding seam program, see Chapter 11.01 Reserving program stations.

9.06.02 Selecting a program station.

P3

- With the machine in its basic position, select the desired program station, e.g. **P3**.

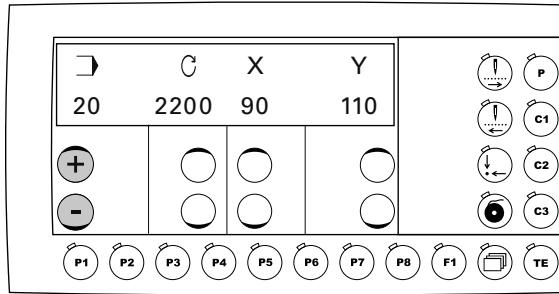

Only those program stations can be selected, which have been reserved previously with a seam pattern with its respective speed and size factors, see Chapter 11.01 Reserving program stations.



Speed and size factors cannot be changed directly in a seam program selected via a program station.

9.06.03 Selecting a sequence

C2

- With the machine in its basic position, select the desired sequence, e.g. **C2**.

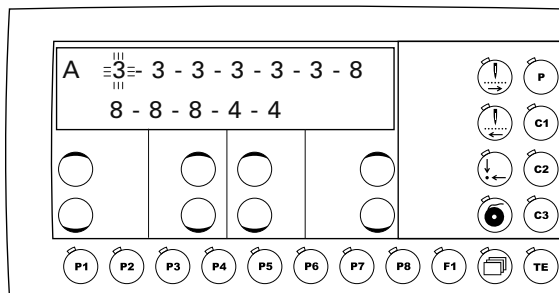

The next seam program waiting to be sewn is depicted by the relevant flashing entry.

Sequences can only be called up if they have been created beforehand (see Chapter 11.02.01 Enter sequences).

9.07 Adjusting the size of the sewing area

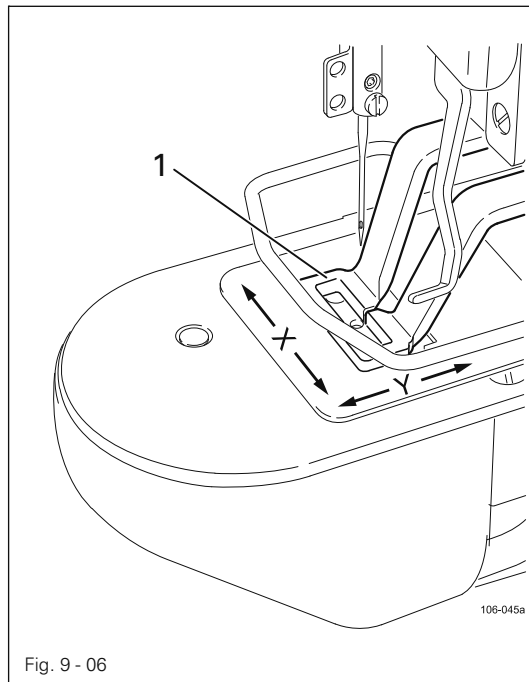

A comparison between the sewing area size entered and the actual sewing area size of the work clamp ensures that seam programs, which are not within the sewing area size, cannot be sewn.



If the actual and the entered sewing area size do not concur with each other, severe damage can be caused to the machine!

- Measure the sewing area size of work clamp 1.



- With the machine in its basic position, select the input mode. (LED is illuminated).

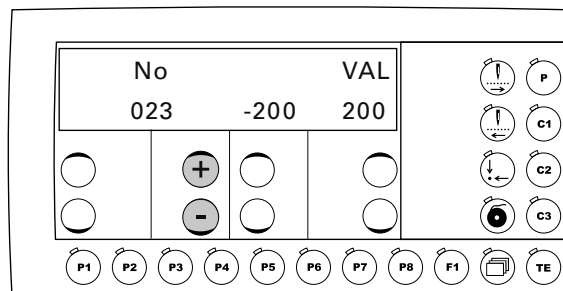

- With the corresponding +/- key select parameter "023".
- If required, enter the access code, see Chapter 11.04.01 Entering the access code.
- With the corresponding +/- key enter the measured value (in 1/10 mm) for the X-axis.
- With the corresponding +/- key select parameter "024".
- With the corresponding +/- key enter the measured value (in 1/10 mm) for the Y-axis.



- Conclude the input by pressing the TE key. (Machine changes to the sewing mode).

9.08 Setting up the bobbin thread counter



- With the machine in its basic position, select the input mode.
- With the corresponding +/- key select parameter "004".
- If required, enter the access code, see Chapter 11.04.01 Entering the access code.

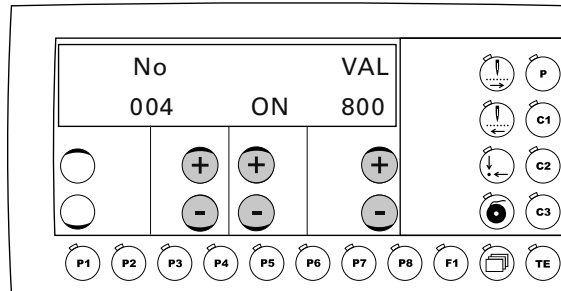

- With the corresponding +/- key switch on the bobbin thread counter.
- With the corresponding +/- key enter the number of workpieces to be sewn.
- Conclude the input by pressing the TE key. (Machine changes to the sewing mode).



9.09 Resetting the piece counter



In the sewing mode (basic position of the machine) the piece counter or the bobbin thread counter can be displayed by pressing the **menu key**. (When the bobbin thread counter is switched off, the piece counter is displayed - Selection under parameter **004**).

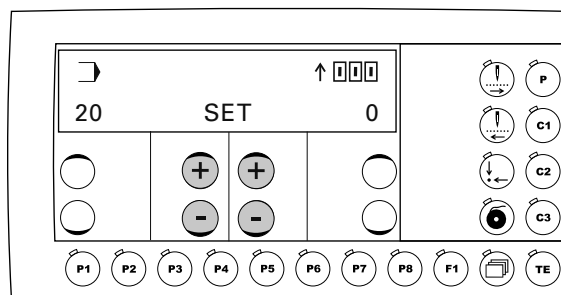

The piece counter counts from **0** onwards and differs from the bobbin thread counter in the display through the upwards pointing arrow.

- Reset the piece counter with the corresponding +/- keys.

9.10 Shifting the seam pattern

To adapt the seam patterns to formed workpiece holders, selected seam patterns can be shifted.



- From the basic position of the machine select the desired program station, e.g. P1.



- Tact through the seam pattern, e.g. forwards.
The actual coordinates are shown together with the shift values for each stitch.

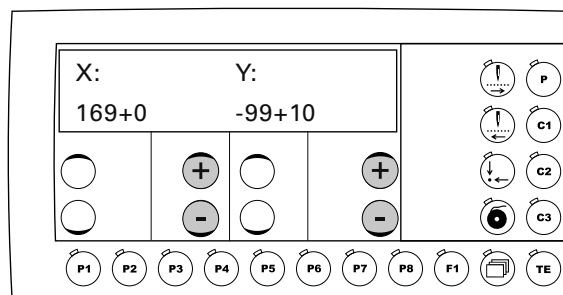

- With the corresponding +/- keys it is possible to enter a shift value for the entire seam pattern in X- or Y-direction at each seam pattern coordinate.



The seam pattern shift is allocated to the respective actual program station and is deleted when the program number is changed.

Inserting and removing the SD-memory card

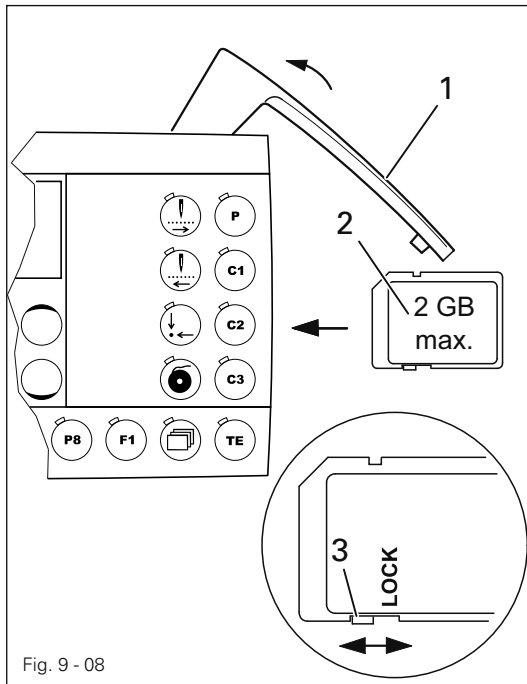

Fig. 9 - 08

Inserting the SD-memory card

- Open cover 1.
- Insert SD-memory card 2 into the card slot with the label at the front.
- Close cover 1 again.

Removing the SD-memory card

- Open cover 1.
- Press the edge of the SD-memory card 2 lightly – the SD-card is ejected.
- Close cover 1 again.



By moving slide 3 it is possible to activate (position "LOCK") or deactivate the write protection function of the SD-memory card. To store, process or delete data on the SD-memory card, the write protection function must be deactivated.



The machine must be installed, connected and set up as described in Chapter 8 Installation and Commissioning.



The machine must not be operated without the safety devices 1 to 5, see Chapter 1.06 Danger warnings! Danger of injury!

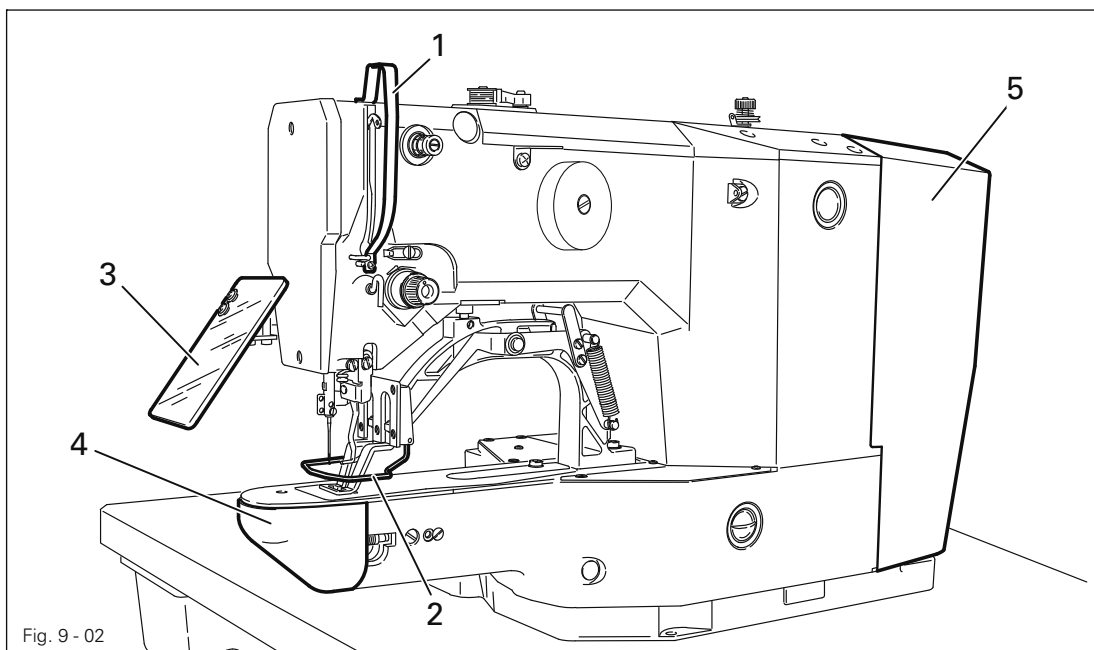

10.01 Operating cycle

- Carry out all steps in accordance with Chapter 9 Setting up.
- Place the material properly under the work clamp.
- Lower the work clamp and start the sewing cycle, see Chapter 7.02 Pedal.

10.02 Sewing in the "Direct program selection" mode

In this function, a seam pattern is selected. After selection, the speed and size can be altered, see Chapter 9.06.01 Selecting and changing the seam pattern.

10.03 Sewing in the "Program stations" mode

Program stations can be selected, which have been reserved beforehand with a seam pattern with relevant speed and size factors, see Chapter 11.01 Reserving program stations.

10.04 Sewing in the "Sequences mode".

Sequences, which have been created beforehand, can be called up with the function keys C1 to C3 (see Chap. 11.02.01 Entering sequences)

10.04.01 Interrupting a sequence

If an interruption occurs during a sequence cycle (e.g. broken thread), it is possible to continue at the same sequence point after the error has been eliminated.

The procedure is as follows:

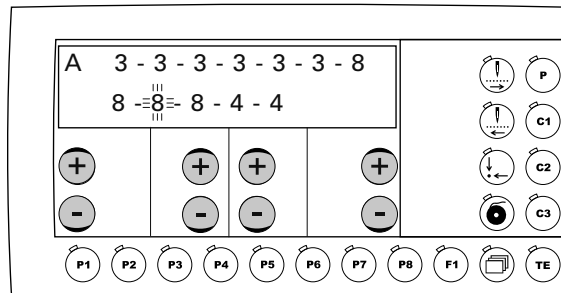

- The activated sequence point flashes.
- Select the sequence A, B or C by pressing the left +/- key.
- Press the corresponding +/- key to move to the sequence point to be repeated.
- Conclude input by pressing the TE key.



10.05 Error messages

When an error occurs, the text "ERROR" appears on the display together with an error code and short instructions. In addition the diode in the memory card slot lights up red (see arrow). An explanation of the error codes can be found in the Chapter 11.07 Error messages on the display.

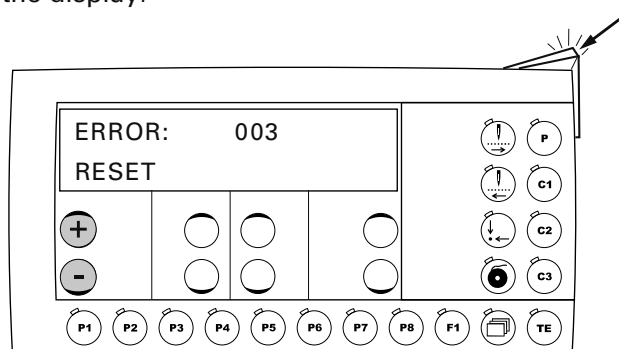

- Correct the error.
- Acknowledge the correction of the error by pressing the corresponding +/- key or by switching the machine off and on.
- The diode in the memory card slot (see arrow) turns yellow again

11 Input

After the machine has been switched on, it is in the input mode. The LED in the "TE" key is illuminated. The input mode is used to reserve program stations, to enter sequences and to change machine parameters. In addition information and input possibilities for the service area are available in this mode.

11.01 Reserving program stations

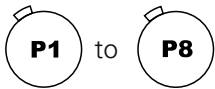

The station keys P1 to P8 are used to enter and select seam programs. A complete seam program is configured from the following parameter:

- seam pattern
- speed
- size factor in X-direction
- size factor in Y-direction



- Call up the input mode by pressing the TE key (LED is illuminated).

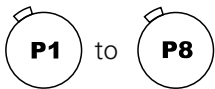

- Press a station key to call up the direct seam pattern selection function.

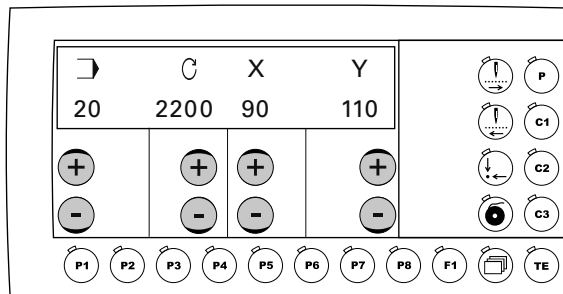

- ➔ ● With the corresponding plus/minus key select the desired seam pattern, e.g. 20. The seam patterns are stored in the machine under program numbers, see Chapter 11.05 **Summary of the seam patterns**.

- ⌚ ● Select the desired speed with the corresponding +/- key.

- X ● Enter the desired size factor (in %) (X-direction) with the corresponding +/- key.

- Y ● Enter the desired size factor (in %) (Y-direction) with the corresponding +/- key.



The enlargement of the seam pattern is limited by the size of the machine's sewing area.



- Conclude the input by pressing the TE key. (The machine changes to the sewing mode).

11.02 Sequences

11.02.01 Entering sequences

C1 to **C3** The sequence program keys **C1** to **C3** are used to enter and select sequence programs. The sequence programs are put together from seam programs, which have been deposited under the station keys **P1** to **P8**.

A sequence can consist of up to 3 segments (A, B + C). In each segment up to 14 entries can be made.



● Call up the input mode by pressing the **TE** key (LED is illuminated).



● In the input mode, select the desired sequence program key, e.g. **C2**.



● Enter the desired seam programs in any order by using the station keys, e.g. **P3** six times ,



P8 four times,



P4 twice

2x



Press the **TE** key input twice (machine changes to the sewing mode).

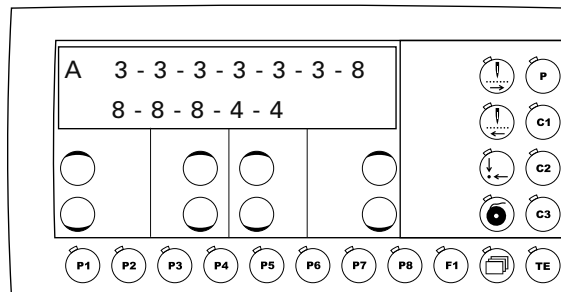

The station keys for selection must have been reserved beforehand, see Chapter 11.01 Reserving program stations.



In the "Input" mode it is possible to scroll between the sequence zones A, B and C by pressing the **Menu** key.

11.02.02 Checking the sequence contents



- With the machine in its basic position, select the desired sequence, e.g. **C2**.
- The activated sequence point flashes.
- Press the corresponding +/- key to move to the sequence point to be checked (e.g. 8).

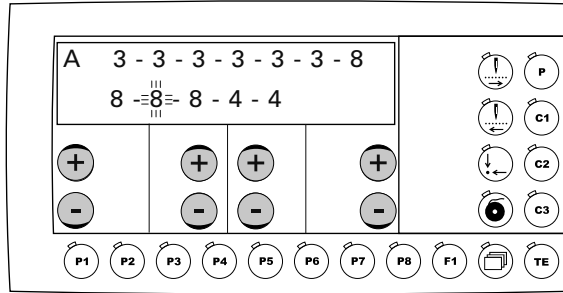

- Press the **TE** key (LED is not illuminated).



- The parameters, such as number of the seam pattern, speed and size factors of the flashing sequence entry are shown if the **Menu** key is pressed.



- Quit the check mode by pressing the Menu key twice.

11.02.03 Deleting sequences



- Call up the Input mode by pressing the **TE** key (LED is illuminated).

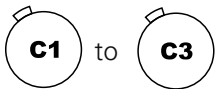

- Call up the sequence to be changed by pressing the **C1**, **C2** or **C3** keys.



Deleting individual entries

- Press a **+/-** key to set the cursor beneath the entry to be deleted and delete the entry by pressing the reverse tacting key twice.

Inserting individual entries

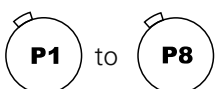

- Press a **+/-** key to set the cursor beneath the position for the insertion.
- Insert the desired entry by pressing the corresponding station key.

Deleting a complete sequence



- Press a **+/-** key to set the cursor at the beginning of the sequence. Press the **reverse tacting** key as often as necessary to delete all entries on the display.



- Press the **TE** input key **twice** (machine changes to the sewing mode).

11.02.04 Combining sequences

Several sequences can be combined to one seam program. To carry out the adjustment, enter the corresponding value for parameter **005** (see Chapter **11.07 List of parameters**).

11.03 Parameter input

After the machine has been switched on, it is in the input mode..

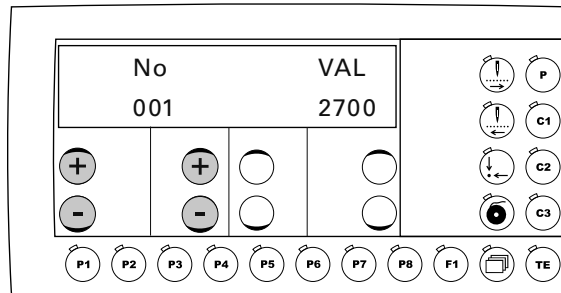

- With the corresponding +/- key select the desired parameter, e.g. 003 lock seam patterns.

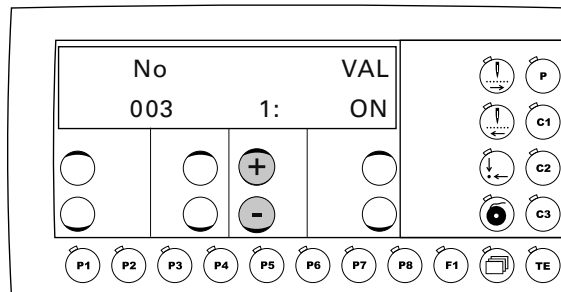

- With the corresponding +/- key select the desired seam pattern.

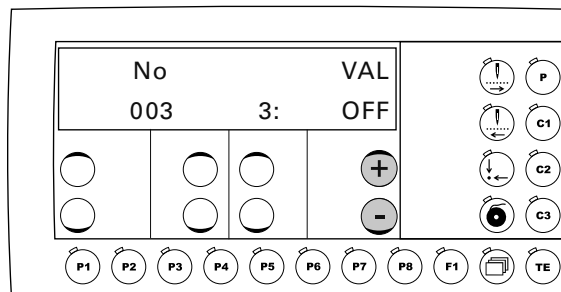

- With the corresponding +/- key lock the desired seam pattern.



- Conclude the input by pressing the TE key. (The machine changes to the sewing mode).



There is a list explaining all the parameters in Chapter 11.06 List of parameters.

11.04 Access codes

The selection of seam patterns, the reservation of the program stations, the input of sequences and the selection of individual parameter levels can be locked with a 4-figure access code. The access code can be changed as desired. The factory set access code is "3371".

11.04.01 Entering the access code

If, in the input mode, a function is selected, which has an access code, the demand for entering the access code appears on the display.

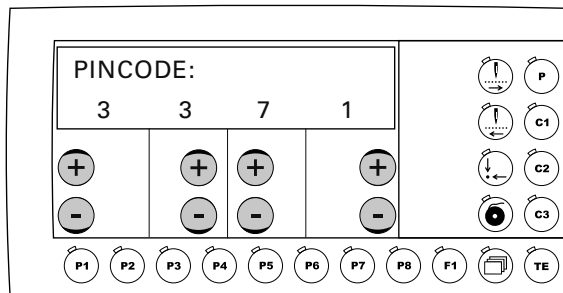

- Enter the access code with the corresponding +/- keys.



- Conclude the input by pressing the **TE** key (machine changes to the sewing mode).



Once the access code has been entered, all functions with access protection are freely accessible, until the machine is switched off.

11.04.02 Changing the access code

- In the input mode, select parameter "811"
- Enter the access code, see Chapter 11.04.01 **Entering the access code**

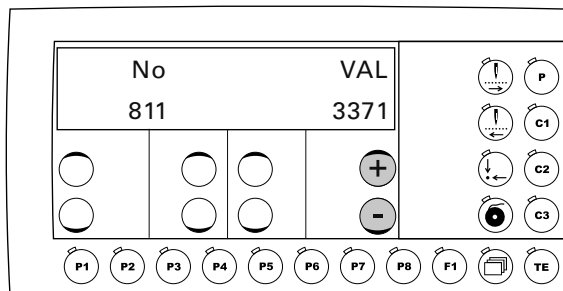

- Change the access code with the corresponding +/- keys.



- Conclude the input by pressing the **TE** key (machine changes to the sewing mode).

11.04.03 Granting access rights

- In the input mode select the corresponding parameter ("801" to "806"), see Chapter 11.07 List of parameters.
- If required, enter the access code, see Chapter 11.04.01 Entering access codes.

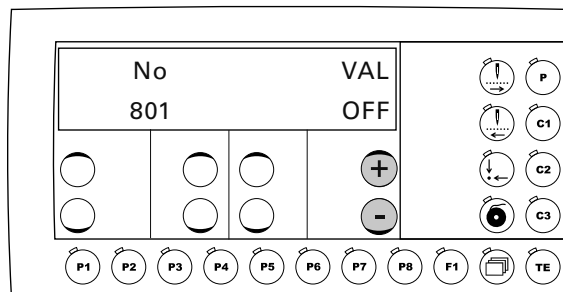









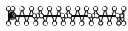

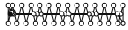
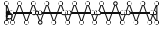

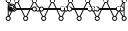

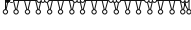
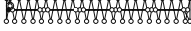







- With the corresponding +/- key approve (on) or lock (OFF) access..







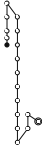
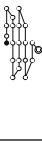
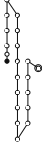

- Conclude the input by pressing the TE key (machine changes to the sewing mode).

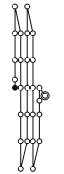
11.05 Summary of the seam patterns

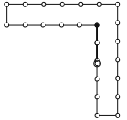
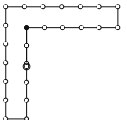
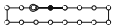
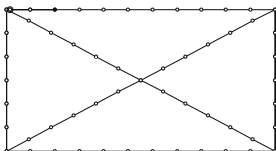
No.	Seam pattern	Size of sewing area [mm]	No. of stitches
P1		16,0 x 2,0	42
P2		10,0 x 2,0	39
P3		16,0 x 2,5	42
P4		24,0 x 3,0	42
P5		10,0 x 2,0	27
P6		16,0 x 2,5	30
P7		10,0 x 2,0	35
P8		16,0 x 2,5	38
P9		24,0 x 3,0	53
P10		24,0 x 3,0	61
P11		6,0 x 2,5	20
P12		6,0 x 2,5	25
P13		6,0 x 2,5	34
P14		8,0 x 2,0	15
P15		8,0 x 2,0	22
P16		8,0 x 2,0	29
P17		10,0 x 0,0	21
P18		10,0 x 0,0	28

No.	Seam pattern	Size of sewing area [mm]	No. of stitches
P19		25,0 x 2,0	28
P20		25,0 x 2,0	36
P21		25,0 x 0,0	41
P22		25,0 x 0,0	44
P23		4,0 x 20,0	27
P24		4,0 x 20,0	35
P25		4,0 x 20,0	41
P26		4,0 x 20,0	56
P27		0,0 x 20,0	18
P28		0,0 x 10,0	21
P29		0,0 x 20,0	21

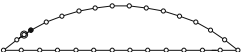
No.	Seam pattern	Size of sewing area [mm]	No. of stitches
P30		0,0 x 20,0	28
P31		10,0 x 10,0	28
P32		10,0 x 10,0	28
P33		15,0 x 15,0	28
P34		15,0 x 15,0	28
P35		14,0 x 2,0	21
P36		36,0 x 19,0	74
P37		6,5 x 9,0	34
P38		6,5 x 9,0	34
P39		11,0 x 11,0	72
P40		31,7 x 6,0	32

11.06 Program Management

In the program management the programs filed in the machine memory or on connected SD-memory cards are displayed and can be deleted or copied. Commercially available SD-memory cards with a storage capacity of max. 512 MB can be inserted in the control panel. The data is stored in machine-relevant sub-directories. The way to insert or remove the SD-memory card is described in Chapter 9.07

- The programs **50 – 99** are stored in the files **50 – 99** and
- the machine data in the file **MD**.

Should the SD-memory cards need to be formatted by the PC, they must be formatted in the format "FAT16". Alternatively the SD-memory cards can also be formatted on the corresponding machine with the formatting function, see Chapter 11.10.08 **Formatting the SD-memory card**.

11.06.01 Calling up the program management

- Switch on the machine.



- Call up the program management

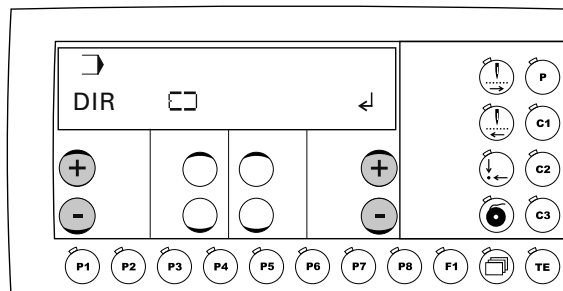

After the program management has been called up, the first menu item appears (display of data in the machine memory).

Confirm the selection of the menu item with the "Enter" function by pressing the right **plus key**. In this example the contents of the machine memory are then displayed.

It is possible to scroll through the other menu points by pressing the left +/- key (see following chapters).

The following menu items are available in the program management:

- Display data in the machine memory
- Display data on the connected SD-memory card
- Copy data to the SD-memory card
- Copy data to the machine memory (from the SD-memory card)
- Delete data in the machine memory
- Delete data on SD-memory card
- Format SD-memory card

11.06.02 Display of the data in the machine memory

- Call up the program management, see Chapter 11.06.01 Calling up the program management.

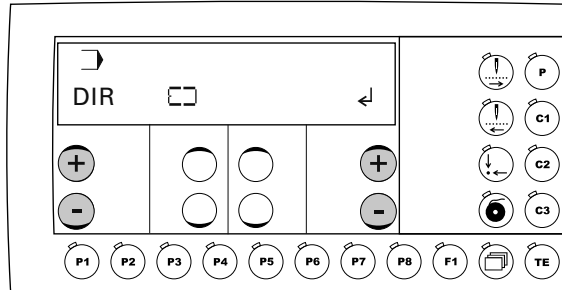

- Press the left +/- keys until the corresponding menu item appears.
- Confirm the selection of the menu item with the "Enter" function by pressing the right plus key.

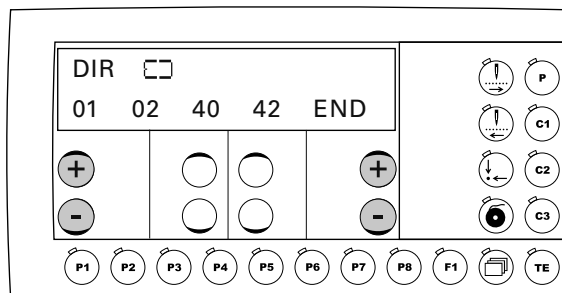

- By pressing the right +/- keys it is possible to scroll through the display of the machine memory.
- When the left +/- keys are pressed, the other menu items of the program management are called up.

11.06.03 Display of the data on the SD-memory card

- Call up the program management, see Chapter 11.06.01 Calling up the program management.

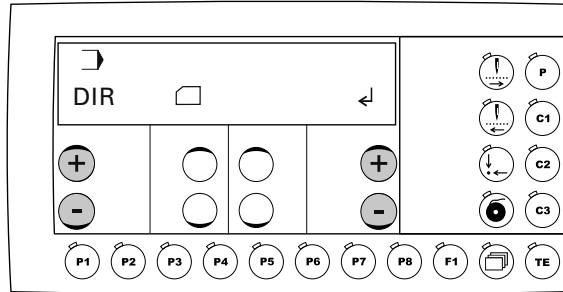

- Press the left +/- keys until the corresponding menu item appears.
- Confirm the selection of the menu item with the "Enter" function by pressing the right plus key.

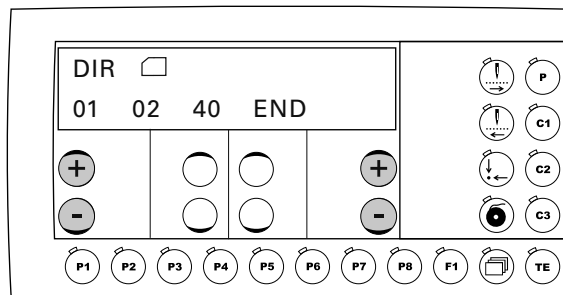

- By pressing the right +/- keys it is possible to scroll through the display of the SD-memory card.
- When the left +/- keys are pressed, the other menu items of the program management are called up.

11.06.04 Copying data onto the SD-memory card

- Call up the program management, see Chapter 11.06.01 Calling up the program management.

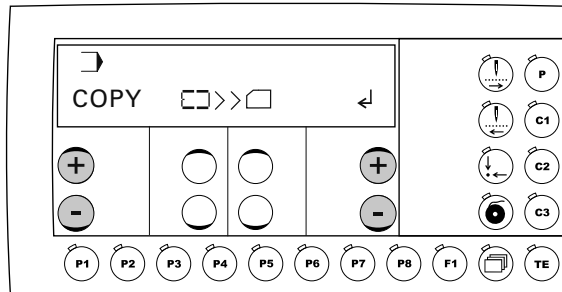

- Press the left +/- keys until the corresponding menu item appears.
- Confirm the selection of the menu item with the "Enter" function by pressing the right plus key.

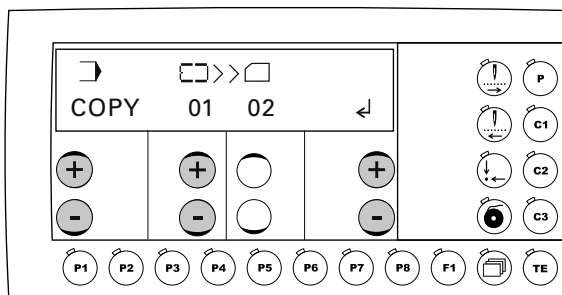

- Press the corresponding +/- keys to select the data to be copied from the machine memory onto the SD-memory card:

MD = machine parameters
 50 - 99 = programs
 ALL = all programs

- The copying process is started with the "Enter" function by pressing the right plus key.



If the data for copying already exists, a safety enquiry appears before overwriting the data. Press the right plus key to confirm the copying process. The copying process can be stopped by pressing the right minus key.

- When the left +/- keys are pressed, the other menu items of the program management are called up.

11.06.05 Copying data into the machine memory

- Call up the program management, see Chapter 11.06.01 Calling up the program management.

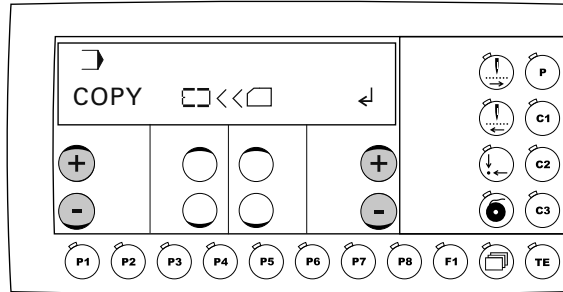

- Press the left +/- keys until the corresponding menu item appears.
- Confirm the selection of the menu item with the "Enter" function by pressing the right plus key.

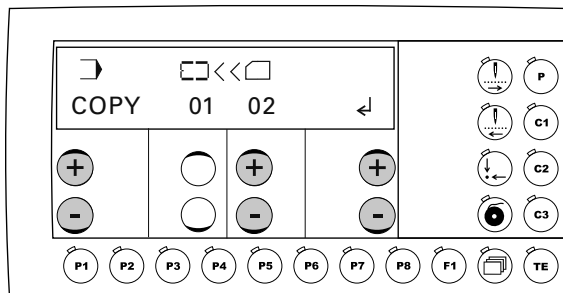

- Press the corresponding +/- keys to select the data to be copied from the SD-memory card into the machine memory:

MD = machine parameters
50 - 99 = programs
ALL = all programs

- The copying process is started with the "Enter" function by pressing the right plus key.



If the data for copying already exists, a safety enquiry appears before overwriting the data. Press the right plus key to confirm the copying process. The copying process can be stopped by pressing the right minus key.

- When the left +/- keys are pressed, the other menu items of the program management are called up.

11.06.06 Deleting data in the machine memory

- Call up the program management, see Chapter 11.06.01 Calling up the program management.

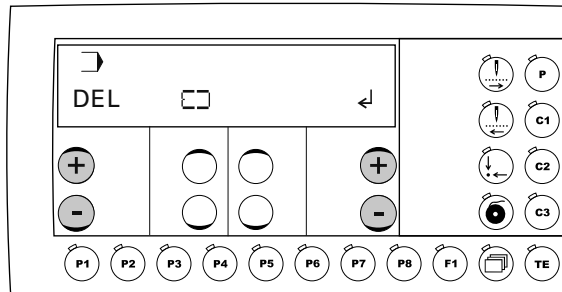

- Press the left +/- keys until the corresponding menu item appears.
- Confirm the selection of the menu item with the "Enter" function by pressing the right plus key.

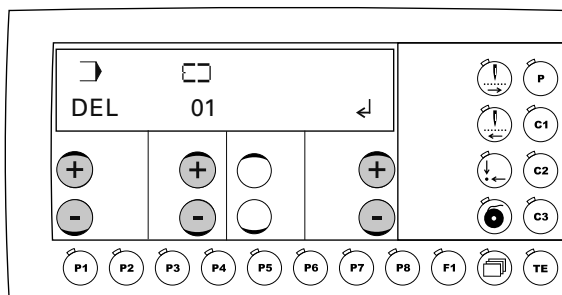

- Press the corresponding +/- keys to select the data to be deleted from the machine memory:

50 - 99 = programs
 ALL = all programs
 Machine data cannot be deleted.

- The deleting process is started with the "Enter" function by pressing the right plus key.



Before the data is deleted, a safety enquiry ensues.

Press the right plus key to confirm the deleting process.

The deleting process can be stopped by pressing the right minus key.

- When the left +/- keys are pressed, the other menu items of the program management are called up

11.06.07 Deleting data from the SD-memory card

- Call up the program management, see Chapter 11.06.01 Calling up the program management.

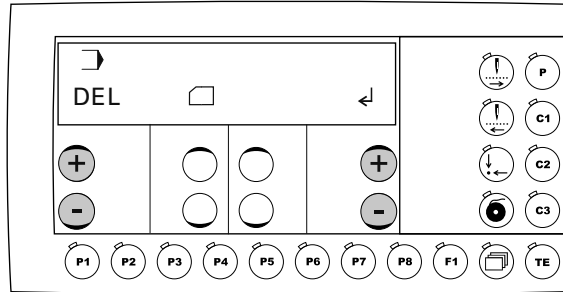

- Press the left +/- keys until the corresponding menu item appears.
- Confirm the selection of the menu item with the "Enter" function by pressing the right plus key.

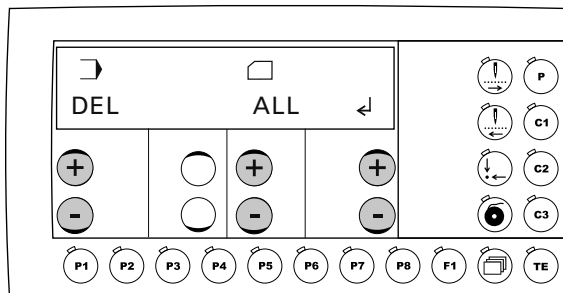

- Press the corresponding +/- keys to select the data to be deleted from the SD-memory card:

MD = machine parameters
 50 - 99 = programs
 ALL = all programs

- The deleting process is started with the "Enter" function by pressing the right plus key.



Before the data is deleted, a safety enquiry ensues.

Press the right plus key to confirm the deleting process.

The deleting process can be stopped by pressing the right minus key.

- When the left +/- keys are pressed, the other menu items of the program management are called up

11.06.08 Formatting the SD-memory card

- Call up the program management, see Chapter 11.07.01 Calling up the program management.

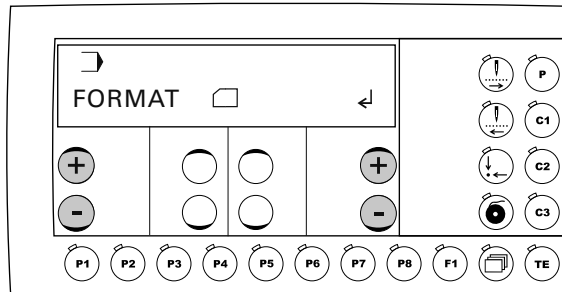

- Press the left **+/-** keys until the corresponding menu item appears.
- The formatting process is started with the "Enter" function by pressing the right **plus** key.



Before formatting begins, a safety enquiry ensues.

Press the right **plus** key to confirm the formatting process.

The formatting process can be stopped by pressing the right **minus** key.

- When the left **+/-** keys are pressed, the other menu items of the program management are called up



The parameter setting values may only be altered by appropriately trained staff!

Group	Parameter	Description	Setting range	Set value
000	001	Maximum speed This parameter is used to fix the max. sewing speed (upper limit).	500 - 2700	2700
	002	Sewing speed for start stitches With this parameter the speeds for the 5 start stitches are fixed. Speed (spm) for start stitch no. 1 Speed (spm) for start stitch no. 2 Speed (spm) for start stitch no. 3 Speed (spm) for start stitch no. 4 Speed (spm) for start stitch no. 5	500 - 2700 500 - 2700 500 - 2700 500 - 2700 500 - 2700	500 900 2700 2700 2700
	003	Locking/releasing seam patterns This parameter is used to release (ON) or lock (OFF) the individual seam patterns (0 to 99) to be carried out in the sewing mode.	ON - OFF	ON
	004	Switch bobbin thread counter on/off Standard value (pieces per bobbin) In the sewing mode, the bobbin thread counter counts the pieces sewn backwards from the standard value. If the bobbin thread counter is switched on, in the sewing mode a signal is given when the value 0 is reached.	ON - OFF 1 - 9999	OFF 11
	005	Sequence combination This parameter is used to combine several sequences with each other. 0 = no combination 1 = C1 with C2 2 = C2 with C3 3 = C1 with C3 4 = C1 with C2 and C3	0 - 4	0

Group	Parameter	Description	Setting range	Set value
000	006	Reversing after thread trimming Reverse position [°] With this parameter it is possible to switch the automatic reversing function after thread trimming on or off. If the reversing function is switched on, the reverse position can be set by turning the balance wheel. The access code is necessary for this adjustment.	ON - OFF 0 - 14	ON 11
	007	Starting point = scale reference point With this parameter it is possible to choose whether the scale reference point is the starting point (ON) or the zero point (OFF).	ON - OFF	OFF
	008	Speed for the "winding" function This parameter is used to fix the speed for the winding operation.	200 - 2700	1500
	009	Via zero point to starting point after end of sequence With this parameter it is possible to choose that, after the end of the sequence, the X-, Y-drive moves to the seam starting point via the reference initiators.	ON - OFF	OFF
	010	Via zero point to starting point after number of program cycles Number of program cycles With this parameter it is possible to choose that, after a certain number of program cycles, the X-, Y-drive moves to the seam starting point via the reference initiators.	ON - OFF 1 - 100	OFF
	011	Pedal mode Switchover between level mode (0) and flip flop mode (1).	0 - 1	0
	012	Needle or balance wheel position in degrees	0 - 360	11

Group	Parameter	Description	Setting range	Set value
000	013	NIS "needle in material" [°] This parameter is used to set the NIS signal. If the function is executed, the position can be entered by turning the balance wheel. If the position is altered, the result is a change in the point of time when the carriage is moved. The access code is necessary for this adjustment.	65 -166	107
	014	Thread trimming speed [min⁻¹] This parameter is used to fix the speed for thread trimming.	100 - 700	300
	015	Reduced current for stepping motors The reduction function of the holding current at rest with closed work clamp is switched on or off.	ON - OFF	ON
	016	Key tone The key tone, as reaction to a key on the control panel being pressed, is switched on or off. The double tone for incorrect inputs always remains switched on.	ON - OFF	ON
	017	Clamp solenoid Operating time [10 ms] The time, for which the solenoid is under full current, is entered.	5 - 100	10
	018	Clamp solenoid duty-cycle [%] At the end of the clamp solenoid operating time (Parameter "017") the solenoid is clocked. The relationship between duration of operation and non-operation is entered here.	5 - 100	20
	019	Thread trimming solenoid operating time [10 ms] The time, for which the solenoid is under full current, is entered.	5 - 100	25
	020	Thread trimming solenoid duty-cycle At present without a function	5 - 100	100

Group	Parameter	Description	Setting range	Set value
000	021	Thread take-up lever t.d.c. [°] The position for the t.d.c. thread take-up lever is entered here. If the function is executed, the position can be set by turning the balance wheel. The access code is necessary for this adjustment.	45 - 53	51
	022	Thread trimming position (in relation to t.d.c. needle) [°] The position, at which the thread trimming solenoid is switched on, is entered here. The adjustment is set by turning the balance wheel. The access code is necessary for this adjustment.	180 - 253	180
	023	Sewing area size X [1/10 mm] To avoid mechanical collisions, the sewing area size of the clamp in use is entered. The control unit checks the path and, if necessary, issues an error message.	± 200	-100/ +100
	024	Sewing area size Y [1/10 mm] To avoid mechanical collisions, the sewing area size of the clamp in use is entered. The control unit checks the path and, if necessary, issues an error message.	± 100	-15/ +15
	025	Thread wiper solenoid operating time [10 ms]		
	026	Thread wiper solenoid, ratio on-time to off-time in % (Duty-Cycle)		
	027	Basic position / loading point = zero point	ON - OFF	OFF
100	101	Software version main processor The software version of the main processor is displayed		0335/xxx
	102	Software version sewing drive unit The software version of the sewing drive module is displayed.		V.xx
	103	Software version control panel The soft- and hardware version of the control panel are displayed.		V.xxx/ H.xxx

Group	Parameter	Description	Setting range	Set value																																		
600	601	<p>Display inputs</p> <p>With this function the digital inputs can be checked. "IN" shows the input numbers (1 - 16). Under "VAL" the respective switch status is displayed.</p> <table border="0"> <tr> <td>IN</td> <td>VAL</td> </tr> <tr> <td>1</td> <td>IN1, programmable input 1</td> </tr> <tr> <td>2</td> <td>IN2, programmable input 2</td> </tr> <tr> <td>3</td> <td>E3, work clamp raised</td> </tr> <tr> <td>4</td> <td></td> </tr> <tr> <td>5</td> <td></td> </tr> <tr> <td>6</td> <td></td> </tr> <tr> <td>7</td> <td></td> </tr> <tr> <td>8</td> <td></td> </tr> <tr> <td>9</td> <td></td> </tr> <tr> <td>10</td> <td></td> </tr> <tr> <td>11</td> <td></td> </tr> <tr> <td>12</td> <td></td> </tr> <tr> <td>13</td> <td></td> </tr> <tr> <td>14</td> <td></td> </tr> <tr> <td>15</td> <td></td> </tr> <tr> <td>16</td> <td></td> </tr> </table>	IN	VAL	1	IN1, programmable input 1	2	IN2, programmable input 2	3	E3, work clamp raised	4		5		6		7		8		9		10		11		12		13		14		15		16			
	IN	VAL																																				
1	IN1, programmable input 1																																					
2	IN2, programmable input 2																																					
3	E3, work clamp raised																																					
4																																						
5																																						
6																																						
7																																						
8																																						
9																																						
10																																						
11																																						
12																																						
13																																						
14																																						
15																																						
16																																						
	602	<p>Display special inputs</p> <p>With this function it is possible to check the special inputs pedal, reference X (SM1) and reference Y (SM2). "IN" shows the inputs (PED, REFX, REFY). Under "VAL" the respective switch status is displayed.</p> <table border="0"> <tr> <td>IN</td> <td>VAL</td> </tr> <tr> <td>PED</td> <td>Pedal (speed control unit -1; 0; +1; 2)</td> </tr> <tr> <td>REFX</td> <td>Reference input X</td> </tr> <tr> <td>REFY</td> <td>Reference input Y</td> </tr> </table>	IN	VAL	PED	Pedal (speed control unit -1; 0; +1; 2)	REFX	Reference input X	REFY	Reference input Y																												
IN	VAL																																					
PED	Pedal (speed control unit -1; 0; +1; 2)																																					
REFX	Reference input X																																					
REFY	Reference input Y																																					

Group	Parameter	Description	Setting range	Set value
600	603	<p>Connect outputs</p> <p>With this function the outlets can be connected. "OUT" shows the outlet selected (1-16). Under "VAL" the selected output is set (S) with the plus/minus key (+), and reset (R) with the plus/minus key. Interlocks are checked. Non-assigned outlets are not connected.</p> <p>OUT VAL</p> <p>1 S/R Solenoid for work clamp open</p> <p>2 S/R</p> <p>3 S/R Solenoid for thread trimming</p> <p>4 S/R</p> <p>5 S/R</p> <p>6 S/R Program outlet</p> <p>7 S/R Program outlet</p> <p>8 S/R</p> <p>9 S/R</p> <p>10 S/R</p> <p>11 S/R</p> <p>12 S/R</p> <p>13 S/R</p> <p>14 S/R</p> <p>15 S/R</p> <p>16 S/R</p>		
	604	<p>Move stepping motors</p> <p>The stepping motors SM1 (X-axis) and SM2 (Y-axis) are moved individually with the respective plus/minus keys. Interlocks are not checked.</p>		
	605	<p>Turn sewing motor</p> <p>The sewing motor can be operated with a selectable set speed by pressing the pedal. After the sewing motor has been started, the current speed is also displayed.</p>	500 -2700	500

Group	Parameter	Description	Setting range	Set value
600	606	<p>Thread trimming sequence</p> <p>The sequence for a complete thread trimming cycle is started with the +/- key (+) below CUT and below THR.</p>		
	607	<p>Cold start (RESET)</p> <p>With this function the control unit carries out a cold start (RESET) with which the data is reset. After this function has been selected, the machine must be switched off and then on again.</p>		
	608	<p>Setting zero points</p> <p>With this function and the adjustment gauge, the zero points for the X/Y-drive unit can be set. (stepping motor correction values for the reference points REF_X, REF_Y). The access code is required for this adjustment.</p>		
	609	<p>Setting the clamp centre X</p> <p>This function is used to set the centre of the clamp in X-direction. When entering the function, the machine moves to the current clamp centre, after which it is possible to move to the right or left edge of the clamp, depending on the set limits (param. "023"). A correction can be made with the plus/minus keys. The relocation value is displayed.</p>		
	610	<p>Setting the clamp centre Y</p> <p>This function is used to help set the centre of the clamp in Y-direction. After entering this function, the machine moves to the current clamp centre, after pressing a key to the front or the rear limit (param. "024"). The clamp must be shifted manually.</p>		

Group	Parameter	Description	Setting range	Set value
600	611	Automatic clamp opening off With this function the automatic opening of the clamp after thread trimming can be switched off. After the machine has been switched off, the automatic clamp opening function is always activated.	ON - OFF	OFF
	612	Test function continuous start	ON - OFF	OFF
800		The function groups and the functions Programming the Function Keys P , P1-P8 and C1-C3 can be released for manipulation (ON) or locked (OFF). If a function group is suppressed, its parameters cannot be changed until a valid access code has been entered. Once a valid access code has been entered, the suppression is cancelled until the machine is switched off.		
	801	Right of access function group 000	ON - OFF	ON
	802	Right of access function group 100	ON - OFF	ON
	807	Right of access function group 600	ON - OFF	OFF
	808	Right of access function group 700	ON - OFF	OFF
	809	Right of access function group 800	ON - OFF	OFF
	810	Right of access to keys "P", "P1" - "P8" and "C1" - "C3"	ON - OFF	ON
	811	Access code This parameter is used to alter the access code. Upon delivery the machine is set with the access code " 3371 ".		3371

11.08 Error messages on the display

Following error messages are shown on the control panel display

- ERROR: 1 Processor error STACK_OVERFLOW
- ERROR: 2 Processor error STACK_UNDERFLOW
- ERROR: 3 Processor error UNDEF_OPCODE
- ERROR: 4 Processor error PROTECTION_FAULT

ERROR: 5	Processor error ILLEGAL_WORD_OPERAND
ERROR: 6	Processor error ILLEGAL_INSTRUCTION
ERROR: 7	Processor error ILLEGAL_BUS_ACCESS
ERROR: 8	Processor error NMI
ERROR: 10	OTE (Sewing head recognition unit) not attached
ERROR: 11	OTE not programmed (new)
ERROR: 12	OTE check sum error
ERROR: 13	OTE header invalid
ERROR: 14	OTE user data invalid
ERROR: 30(#)	(OTE error see cap. 11.10)
ERROR: 31(#)	(Error Sewing motor see cap. 11.09)
ERROR: 50	Incorrect control panel
ERROR: 51	Incorrect machine class in OTE
ERROR: 52	Incorrect software for main drive
ERROR: 101	Mains voltage
ERROR: 102	Power supply overload
ERROR: 103	24 V too low
ERROR: 201(#)	(Error Sewing motor see cap. 11.09)
ERROR: 202	Pattern too large
ERROR: 203	Overload data transfer sewing motor
ERROR: 204	Tacting function locked
ERROR: 205	Run function locked
ERROR: 206	No NIS
ERROR: 207	Not end of ramp
ERROR: 208	Zero point not found
ERROR: 209	Sewing function locked
ERROR: 210	Bobbin thread fault
ERROR: 211	Stitch too large
ERROR: 301	Raise clamp not completed
ERROR: 302	Lower clamp not completed
ERROR: 303	Raise clamp locked (needle position)
ERROR: 304	Lower clamp locked (needle position)
ERROR: 305	Thread wiper on locked (needle position)
ERROR: 401	Error sewing motor
ERROR: 402	Overload data transfer sewing motor
ERROR: 403	Program station not programmed
ERROR: 404	Program locked
ERROR: 405	Program does not exist
ERROR: 406	No NIS
ERROR: 407	Zero points invalid
ERROR: 408	Machine not in basic position

ERROR: 409	Zero point not found
ERROR: 416	Error in SD-memory card reader
	1: No SD-memory card inserted
	2: Wrong SD-memory card (does not match the machine)
	3: SD-memory card not inserted correctly
	4: SD-memory card with write protection
	5: Data error on SD-memory card
	6: Formatting failed
	7: File does not match machine
	8: Incorrect file size
	9: Transfer error
	10: Data cannot be deleted
	11: Sewing head recognition unit not connected
ERROR: 417	No penetration point found for winding
ERROR: 418	1st penetration point for winding is located outside the sewing area
ERROR: 419	Incorrect number of sewing-on stitches
ERROR: 420	Incorrect number of attaching stitches

11.09 Sewing motor errors

1	Time out	70	Motor blocking
9	Position not reached	71	No incremental connector
33	Invalid parameter value	73	Motor running interrupted
34	Brake path too short	74	Incremental transmitter missing for speed increase / reduction
35	Communication error	75	Controller locked
36	Initialisation (Init.) not completed	170	Invalid transmission
37	Command overflow	171	Zero mark invalid
64	Mains OFF during initialisation	173	Motor blocked in 1st stitch
65	Overcurrent directly after mains ON	175	Start error
66	Short circuit	222	Time-out monitoring
68	Overcurrent in operation		
69	No increments		

11.10 OTE-errors

1	Read error	8	Checksum failed
2	Write error	9	Serialnr. changed
3	Full EEPROM	7	Adressen-Überlauf
4	No EEPROM	8	Checksummen-Fehler
5	Invalid size	9	Falsche Seriennummer
6	Invalid address		
7	Address overflow		

12 Care and maintenance

12.01 Maintenance intervals

Clean the entire machine	once a week
Clean the hook compartment	once a day, more often when in continuous operation
Oiling the needle head parts	as required
Oiling the hook.....	as required
Oiling the bearing points in the arm.....	once a month



During all cleaning work the machine must be disconnected from the power supply by switching off the main switch or pulling out the plug!
Danger of injury if the machine is started accidentally!

12.02 Cleaning the machine

The cleaning cycle required for the machine depends on following factors:

- Single or several shift operation
- Amount of dust resulting from the workpiece

It is therefore only possible to stipulate the best possible cleaning instructions for each individual case.



For all cleaning work the machine must be disconnected from the mains by switching off the on/off switch or by removing the mains plug!
Danger of injury if the machine suddenly starts up



To avoid breakdowns, the following cleaning work is recommended for single shift operation:

- Clean hook compartment and needle area of sewing head several times daily.
- Clean the entire machine at least once a week.

12.03 Cleaning the hook compartment

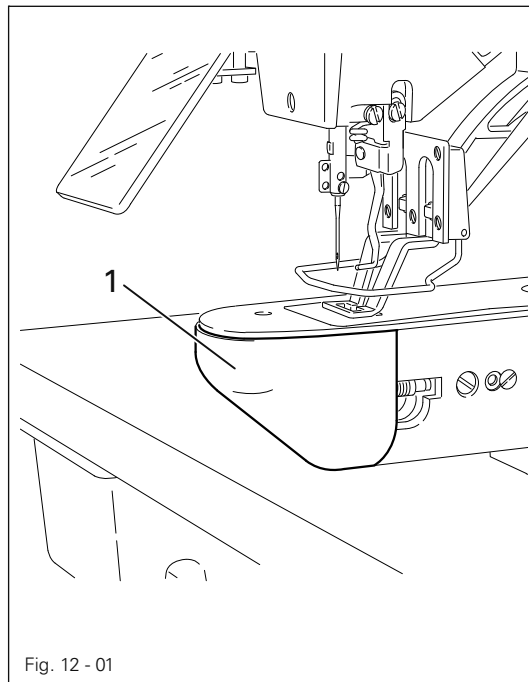

Fig. 12 - 01



Switch off the machine!
Danger of injury if the machine
is started accidentally!

- Open the hook compartment cover 1.
- Clean the hook and the hook compartment daily, more often if in continuous operation.

12.04 Oiling the needle head parts

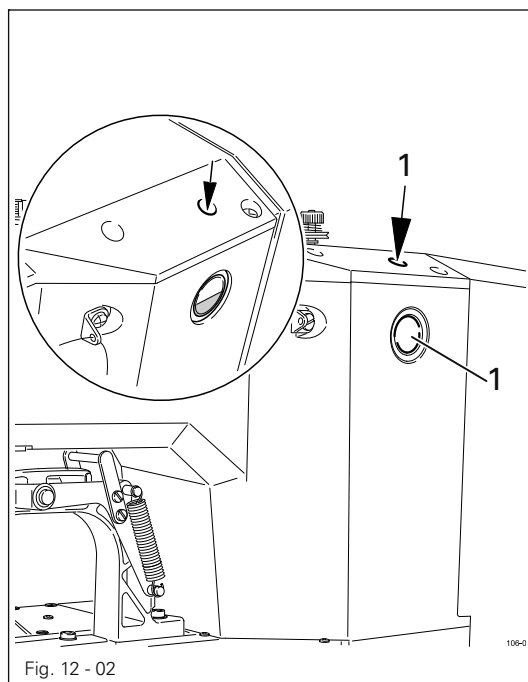
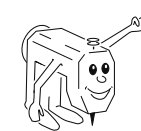

Fig. 12 - 02

- When required, pour oil through hole 1 up to the upper marking in inspection glass 2.



Only use oil with a mean
viscosity of $10.0 \text{ mm}^2/\text{s}$ at 40°C
and a density of 0.847 g/cm^3 at
 15°C .



We recommend
PFAFF sewing machine oil, part
no. 280-1-120 105.

12.05 Oiling the hook

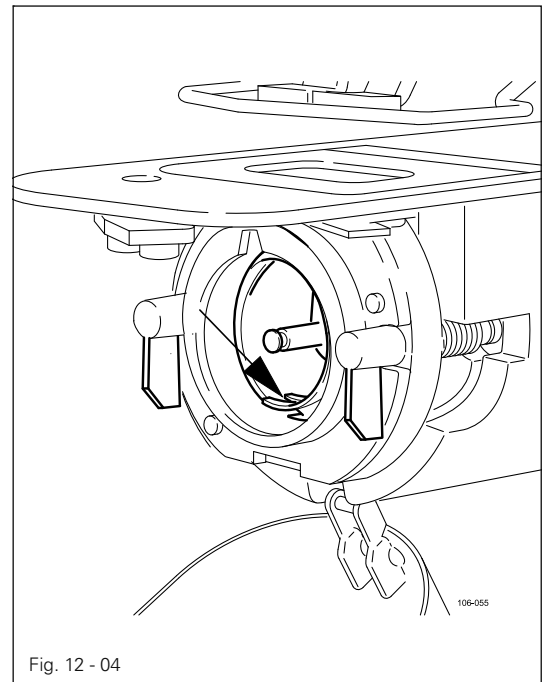
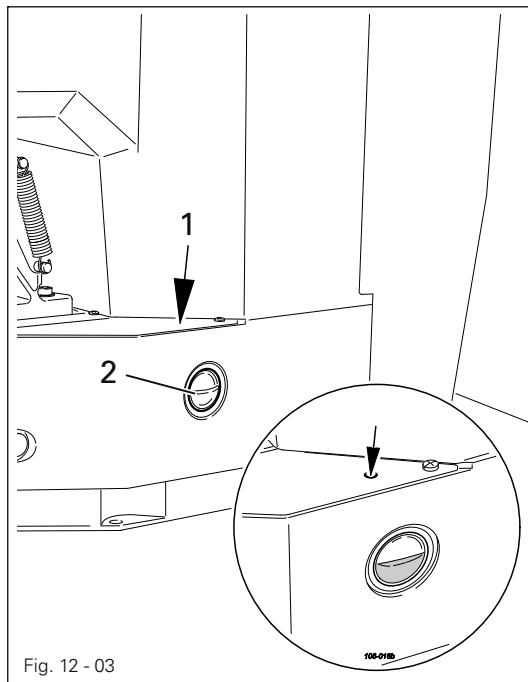

Switch off the machine!

Danger of injury if the machine is started accidentally!

- When required, pour oil through hole 1 up to the upper marking in inspection glass 2.
- Before commissioning the machine, and after long downtimes, also add a few drops of oil to the hook race, see arrow in Fig. 12-04.



Only use oil with a mean viscosity of $10.0 \text{ mm}^2/\text{s}$ at 40°C and a density of 0.847 g/cm^3 at 15°C .

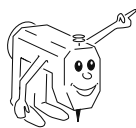

We recommend

PFAFF sewing machine oil, part no. 280-1-120 105.

12.06 Oiling the bearing points in the arm

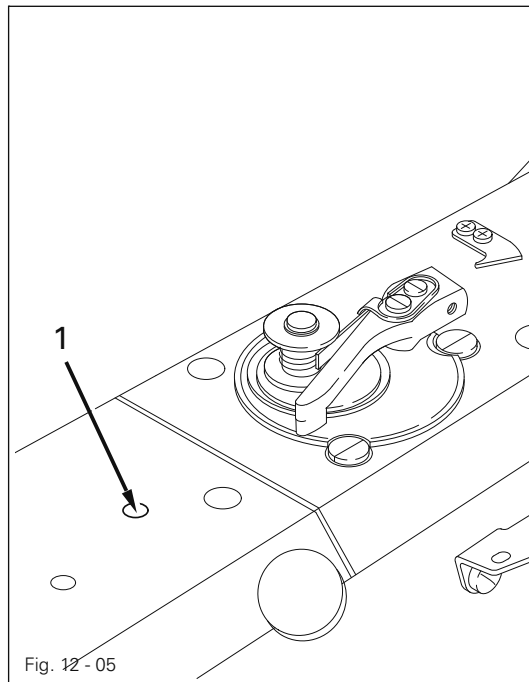

- Once a month pour a few drops of oil into hole 1.



Only use oil with a mean viscosity of $10.0 \text{ mm}^2/\text{s}$ at 40°C and a density of 0.847 g/cm^3 at 15°C .

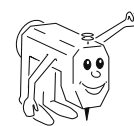

We recommend
PFAFF sewing machine oil, part
no. 280-1-120 105.

12.07 Oil disposal

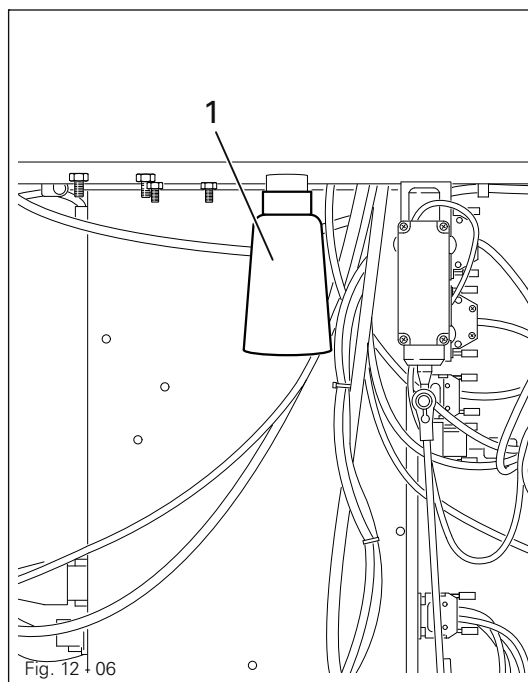

- When required, unscrew oil collector 1 and dispose of the oil in accordance with the valid local environmental regulations.



The oil must not get into the sewer system! Danger of damage to the environment!

12.08 Cleaning the blower air filter

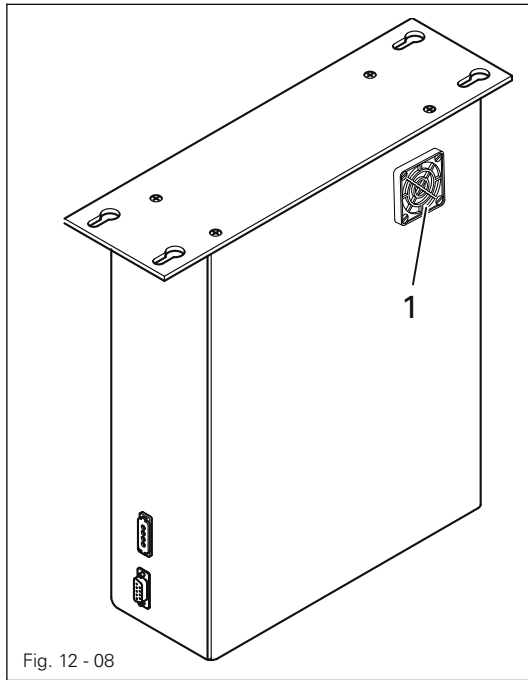
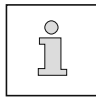

Fig. 12 - 08

- Remove cover 1.
- Take out filter element and clean with compressed air.
- Insert the clean filter element and replace cover 1.

Wearing parts

This is a list of the most important wearing parts.



A detailed parts list for the complete machine is included with the accessories. In case of loss the parts list can be downloaded from the internet address www.pfaff-industrial.de/pfaff/de/service/downloads

As an alternative to the internet download the parts lists can also be ordered in book form under part no. 296-12-18 981.

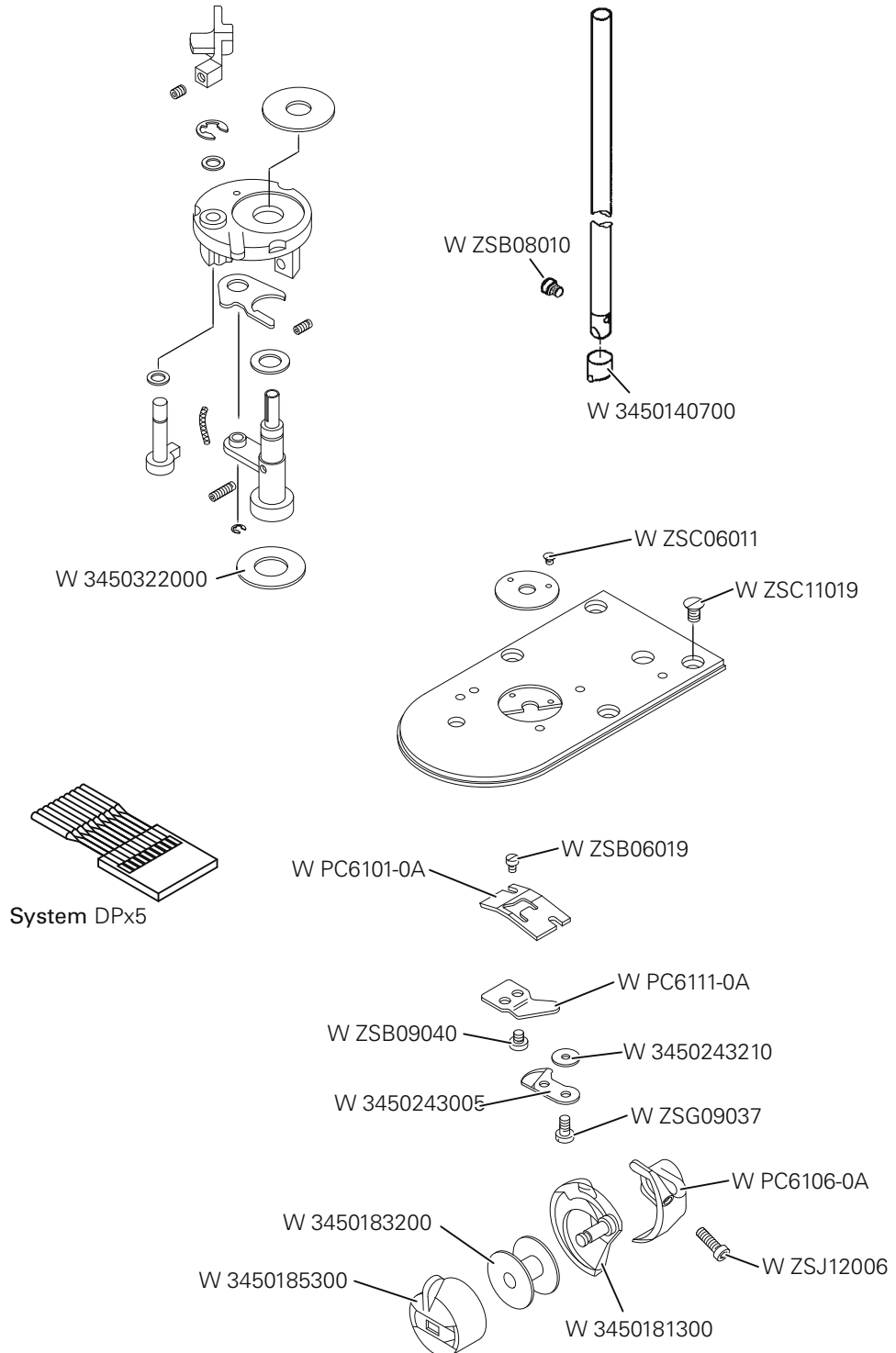



Europäische Union
Wachstum durch Innovation – EFRE



PFAFF Industriesysteme und Maschinen AG

Hans-Geiger-Str. 12 - IG Nord
D-67661 Kaiserslautern

Telefon: +49-6301 3205 - 0
Telefax: +49-6301 3205 - 1386
E-mail: info@pfaff-industrial.com