

***POWERline***

**2235**

INSTRUCTION MANUAL

This instruction manual applies to machines  
from the following serial numbers onwards:

# 2 799 145 →



This Instruction Manual is valid for all models and subclasses listed in the chapter "Specifications".



The adjustment manual for the machines can be downloaded free of charge from the internet address

**[www.pfaff-industrial.com/pfaff/de/service/downloads](http://www.pfaff-industrial.com/pfaff/de/service/downloads)**

As an alternative to the internet download the adjustment manual can also be ordered in book form under part no. **296-12-19 218/002**.

The reprinting, copying or translation of PFAFF Instruction Manuals, whether in whole or in part, is only permitted with our previous authorization and with written reference to the source.

**PFAFF Industriesysteme  
und Maschinen AG**

Hans-Geiger-Str. 12 - IG Nord  
D-67661 Kaiserslautern

Contents .....		Page
<b>1</b>	<b>Safety .....</b>	<b>5</b>
1.01	Directives .....	5
1.02	General notes on safety .....	5
1.03	Safety symbols .....	6
1.04	Important points for the user .....	6
1.05	Operating and specialist personnel .....	7
1.05.01	Operating personnel .....	7
1.05.02	Specialist personnel .....	7
1.06	Danger warnings .....	8
<b>2</b>	<b>Proper use.....</b>	<b>9</b>
<b>3</b>	<b>Specifications .....</b>	<b>10</b>
3.01	PFAFF 2235 BASIC, PFAFF 2235 PLUS and PFAFF 2235 PREMIUM .....	10
3.02	Maximum speed .....	10
3.03	Machine equipment and options .....	11
<b>4</b>	<b>Disposal of Machine .....</b>	<b>12</b>
<b>5</b>	<b>Transportation, packing and storage.....</b>	<b>12</b>
5.01	Transportation to customer's premises .....	12
5.02	Transportation inside the customer's premises .....	12
5.03	Disposal of packing materials .....	12
5.04	Storage .....	12
<b>6</b>	<b>Explanation of symbols.....</b>	<b>13</b>
<b>7</b>	<b>Controls .....</b>	<b>14</b>
7.01	On/off switch .....	14
7.02	Sewing lamp switch (option).....	14
7.03	Pedal .....	15
7.04	Keyboard on machine head (only on the PFAFF 2235 PLUS).....	16
7.05	Keyboard on machine head (only on the PFAFF 2235 PREMIUM).....	18
7.06	Knee lever (only on the PFAFF 2235 BASIC).....	21
7.07	Knee switch (only as an option on the PFAFF 2235 PFAFF PLUS).....	21
7.08	Lever for lifting the presser foot.....	22
7.09	Adjusting the stitch length / Reverse feed lever (PFAFF 2235 BASIC + PLUS) .....	22
7.10	Adjusting the stitch length / Reverse feed lever (PFAFF 2235 PREMIUM) .....	23

	Contents .....	Page
	Contents .....	Page
7.11	Adjusting the top feed stroke (on the PFAFF 2235 BASIC + PLUS).....	23
7.12	Adjusting the top feed stroke (on the PFAFF 2235 PREMIUM) .....	24
7.13	Switchable needle thread tension.....	24
7.14	Control panel.....	25
7.15	Safety coupling (optional) .....	25
<b>8</b>	<b>Preparation .....</b>	<b>26</b>
8.01	Inserting the needle.....	26
8.02	Winding the bobbin thread, regulating the winder tension.....	27
8.03	Removing / Inserting the bobbin case .....	28
8.04	Inserting the bobbin case / Adjusting the bobbin thread tension.....	28
8.05	Threading needle thread/adjusting needle thread tension .....	29
8.06	Setting the bobbin thread control function by reverse stitch counting .....	29
<b>9</b>	<b>Care and maintenance.....</b>	<b>30</b>
9.01	Servicing and maintenance intervals .....	30
9.02	Cleaning the machine .....	30
9.03	Lubricating .....	31
9.04	Checking/regulating the air pressure .....	32
9.05	Emptying/cleaning the water bowl of the air filter/regulator.....	32
<b>10</b>	<b>Wearing parts .....</b>	<b>33</b>

## 1 Safety

### 1.01 Directives

The machine has been constructed in accordance with the requirements listed in the EC Declaration of Conformity and the Declaration of Incorporation.

In addition to this Instruction Manual, also observe all generally accepted, statutory and other regulations and legal requirements and all valid environmental protection regulations! The regionally valid regulations of the social insurance society for occupational accidents or other supervisory organizations are to be strictly adhered to!

### 1.02 General notes on safety

- This machine may only be operated by adequately trained operators and only after having completely read and understood the Instruction Manual!
- All Notes on Safety and Instruction Manuals of the motor manufacturer are to be read before operating the machine!
- The danger and safety instructions on the machine itself are to be followed!
- This machine may only be used for the purpose for which it is intended and may not be operated without its safety devices. All safety regulations relevant to its operation are to be adhered to.
- When exchanging sewing tools (e.g. needle, roller presser, needle plate and bobbin), when threading the machine, when leaving the machine unattended and during maintenance work, the machine is to be separated from the power supply by switching off the On/Off switch or by removing the plug from the mains!
- Everyday maintenance work is only to be carried out by appropriately trained personnel!
- Repairs and special maintenance work may only be carried out by qualified service staff or appropriately trained personnel!
- Work on electrical equipment may only be carried out by appropriately trained personnel!
- Work is not permitted on parts and equipment which are connected to the power supply! The only exceptions to this rule are found in the regulations EN 50110.
- Modifications and alterations to the machine may only be carried out under observance of all the relevant safety regulations!
- Only spare parts which have been approved by us are to be used for repairs! We expressly point out that any replacement parts or accessories which are not supplied by us have not been tested and approved by us. The installation and/or use of any such products can lead to negative changes in the structural characteristics of the machine. We are not liable for any damage which may be caused by non-original parts.

## 1.03 Safety symbols



Danger!  
Points to be observed.



Danger of injury for operating and specialist personnel!



### Caution

Do not operate without finger guard and safety devices.  
Before threading, changing bobbin and needle, cleaning etc. **switch off main switch.**

## 1.04 Important points for the user

- This Instruction Manual is an integral part of the machine and must be available to the operating personnel at all times.
- The Instruction Manual must be read before operating the machine for the first time.
- The operating and specialist personnel is to be instructed as to the safety equipment of the machine and regarding safe work methods.
- It is the duty of the user to only operate the machine in perfect running order.
- It is the obligation of the user to ensure that none of the safety mechanisms are removed or deactivated.
- It is the obligation of the user to ensure that only authorized persons operate and work on the machine.

Further information can be obtained from your PFAFF agent.

## 1.05 Operating and specialist personnel

### 1.05.01 Operating personnel

Operating personnel are persons responsible for the equipping, operating and cleaning of the machine as well as for taking care of problems arising in the sewing area.

The operating personnel is required to observe the following points and must:

- always observe the Notes on Safety in the Instruction Manual!
- never use any working methods which could adversely affect the safety of the machine!
- not wear loose-fitting clothing or jewelery such as chains or rings!
- also ensure that only authorized persons have access to the potentially dangerous area around the machine!
- always immediately report to the person responsible any changes in the machine which may limit its safety!

### 1.05.02 Specialist personnel

Specialist personnel are persons with a specialist education in the fields of electrics, electronics and mechanics. They are responsible for the lubrication, maintenance, repair and adjustment of the machine.

The specialist personnel is obliged to observe the following points and must:

- always observe the Notes on Safety in the Instruction Manual!
- switch off the On/Off switch before carrying out adjustments or repairs, and ensure that it cannot be switched on again unintentionally!
- wait until the luminous diode on the control box is no longer blinking or on before beginning adjustment or repair work.
- never work on parts which are still connected to the power supply! Exceptions are explained in the regulations EN 50110.
- replace the protective coverings and close the electrical control box after all repairs or maintenance work!

## 1.06

### Danger warnings



A working area of 1 m must be kept free both in front of and behind the machine, so that easy access is possible at all times.



Never put your hands or fingers in the sewing area during sewing!  
Danger of injury by the needle!



While setting or adjusting the machine do not leave any objects on the table nor in the needle plate area! Objects may be trapped or flung out of the machine!

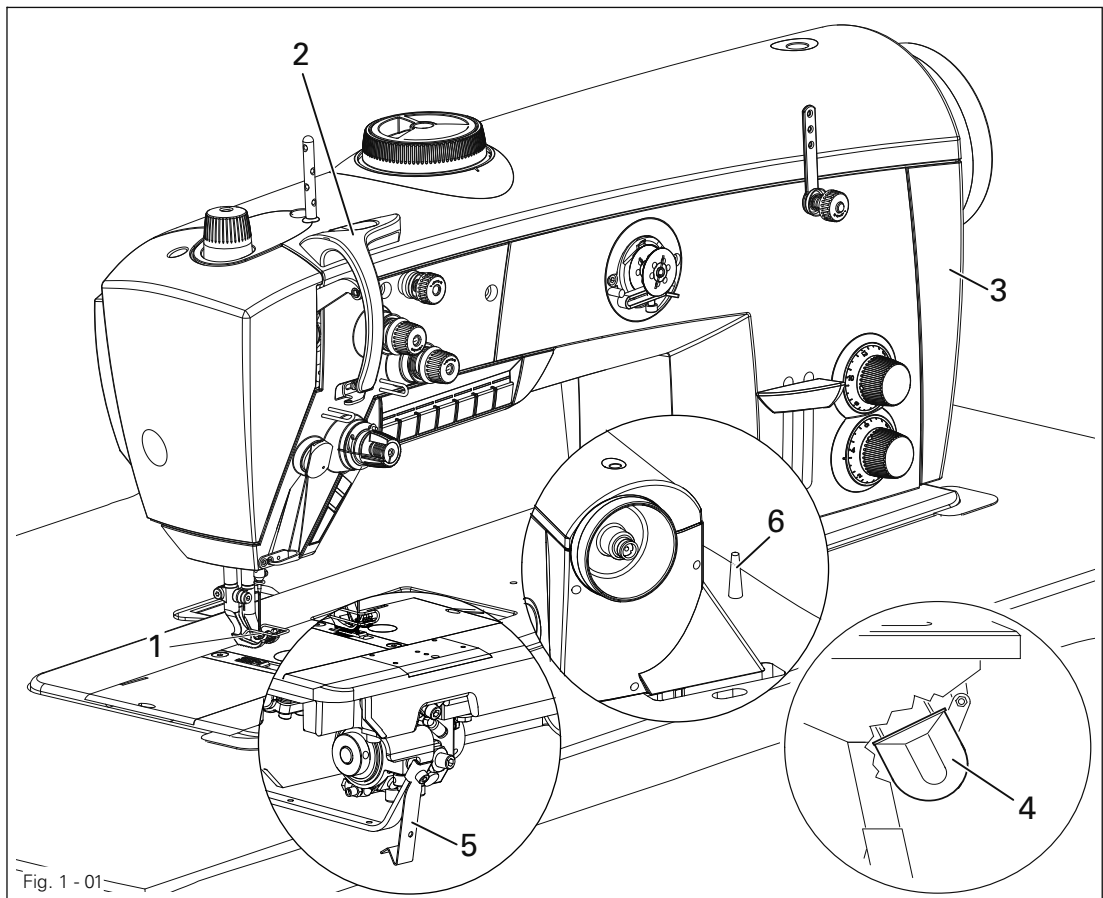

Do not run the machine without finger guard 1!  
Danger of injury by up and down movement of needle!



Do not run the machine without take-up lever guard 2!  
Danger of injury by moving take-up lever!



Do not run the machine without belt guards 3 and 4!  
Danger of injury by rotating v-belt!



Do not operate the machine without tilt lock 5!  
Danger of crushing between sewing head and table!



Do not operate the machine without support 6! Danger due to top-heavy sewing head! Machine can tip over backwards when tilted!



2

**Proper use**

The PFAFF 2235 BASIC, PFAFF 2235 PLUS and the PFAFF 2235 PREMIUM are single needle flatbed sewing machines with unison feed and large horizontal hook for sewing lockstitch seams.

The machine is intended for commercial (industrial) use



Any and all uses of this machine which have not been approved of by the manufacturer are considered to be inappropriate! The manufacturer cannot be held liable for any damage caused by the inappropriate use of the machine!  
The appropriate use of the machine includes the observance of all operational, adjustment, maintenance and repair measures required by the manufacturer!

## 3 Specifications \*

### 3.01 PFAFF 2235 BASIC, PFAFF 2235 PLUS and PFAFF 2235 PREMIUM

Stitch type:	.....301 (lockstitch)
Needle system:	..... 134-35
Version:	..... CN, CN9, C/DN, C/DN9
Needle size in 1/100 mm:	
Version CN, CN9:	..... 110 – 140
Version C/DN, C/DN9:	..... 150 – 200
Max. stitch length:	
Version CN, C/DN:	.....6 mm
Version CN9, C/DN9:	.....9 mm
Max.thread size (synthetic):	
Version CN, CN9:	..... 15/3▲
Version C/DN, C/DN9:	..... 10/3▲
Presser foot clearance:	.....20 mm
Clearance width:	.....350 mm
Clearance height:	..... 120 mm
Bed plate dimensions:	.....640 x 200 mm
Noise data:	
Noise emission level at workplace with a sewing speed of 2400 spm:	..... $L_{pA} < 80$ dB(A)■
(Noise measurement in accordance with DIN 45 635-48-A-1, ISO 11204, ISO 3744, ISO	
Motor data:	..... See instruction manual for the motor
Leakage current	..... $\leq 5$ mA♦
Air consumption per switch cycle:	.....0.146 NI
Net weight of sewing head:	.....approx. 70 kg
Gross weight of sewing head :	.....approx. 80 kg

\* Subject to alterations

♦ Due to the use of network filters there is a nominal leakage current of  $\leq 5$  mA.

▲ synthetic, or other sizes of comparable thread types

■  $K_{pA} = 2,5$  dB

### 3.02 Maximum speed

Top feed lift	Stitch length range	Max. spm on version C	Max. spm on version C/D
1 - 4 mm	up to 9 mm	3000	2800
4,5 mm	up to 9 mm	2900	2700
5 mm	up to 9 mm	2600	2400
5,5 mm	up to 9 mm	2500	2300
6 mm	up to 9 mm	2400	2300
6,5 mm	up to 9 mm	2200	2000
7 mm	up to 9 mm	2000	1800
7,5 - 9 mm	up to 9 mm	1800	1600

## 3.03 Machine equipment and options

PFAFF 2235	BASIC	PLUS	PREMIUM
Horizontal hook, large	●	●	●
Thread trimmer (-900/91), < 12 mm thread ends	-	●	●
Thread pulling device (-909/12), controlled	-	○	●
Presser foot lift, manual via knee lever	●	-	-
Presser foot lift (-910/04), electropneumatic	-	●	●
Manual backtacking with mech. hand switch	●	●	●
Automatic backtacking (-911/35), electropneumatic	-	●	●
1 preselectable stitch length	●	●	-
2 preselectable stitch lengths, can be switched alternately	-	-	●
2 preselectable thread tensions, one can be switched on manually	●	●	-
2 preselectable thread tensions, one can be switched on electropneumatically by hand switch	-	-	●
1 presser foot stroke, manually adjustable, top feed stroke up to max. 9 mm	●	●	-
2 presser foot strokes, manually adjustable, preselectable quick stroke adjustment with hand switch (electropneumatically controlled)	-	-	●
Drop feed, adjustable	●	●	●
Oil level control through inspection glass	●	●	●
Oil level on display, with warning light on machine head	-	-	●
Presser foot pressure, manually adjustable	●	●	●
Clutch motor	●	-	-
DC-motor	○	●	●
Control panel	-	●	●
Remaining bobbin thread recognition function by stitch counting with LED display	-	●	●
Integrated multiple switch on machine head	-	●	-
Integrated multiple switch on machine head + programmed multi switch	-	-	●
Integrated LED sewing lamp on sewing head, dimmable	○	○	●
Bobbin thread winding device	●	●	●
Attachment slider	○	○	○
Skip stitch detector SSD	-	-	○
Safety coupling	○	○	●
Machine version CN, CN9 for processing medium-heavy materials, threads up to 15/3 (synthetic)	●	●	●
Machine version C/DN, C/DN9 for processing heavy materials, threads up to 10/3 (synthetic)	○	○	○

● = standard, ○ = optional

---

## *Disposal of Machine*

---

### 4 Disposal of Machine

- Proper disposal of the machine is the responsibility of the customer.
- The materials used for the machine are steel, aluminium, brass and various plastic materials. The electrical equipment comprises plastic materials and copper.
- The machine is to be disposed of according to the locally valid pollution control regulations; if necessary, a specialist is to be commissioned.



Care must be taken that parts soiled with lubricants are disposed of separately according to the locally valid pollution control regulations!

---

## *Transport, Verpackung und Lagerung*

---

### 5 Transportation, packing and storage

#### 5.01 Transportation to customer's premises

The machines are delivered completely packed.

#### 5.02 Transportation inside the customer's premises

The manufacturer cannot be made liable for transportation inside the customer's premises nor to other operating locations. It must be ensured that the machines are only transported in an upright position.

#### 5.03 Disposal of packing materials

The packing materials of this machine comprise paper, cardboard and VCE fibre. Proper disposal of the packing material is the responsibility of the customer.

#### 5.04 Storage

If the machine is not in use, it can be stored as it is for a period of up to six months, but it should be protected against dust and moisture.

If the machine is stored for longer periods, the individual parts, especially the surfaces of moving parts, must be protected against corrosion, e.g. by a film of oil.

## 6 Explanation of symbols

In this instruction manual, work to be carried out or important information is accentuated by symbols. These symbols have the following meanings:



Note, information



Cleaning, care



Lubrication

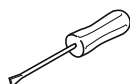

Maintenance, repairs, adjustment, service work  
(only to be carried out by technical staff)

## 7 Controls

### 7.01 On/off switch

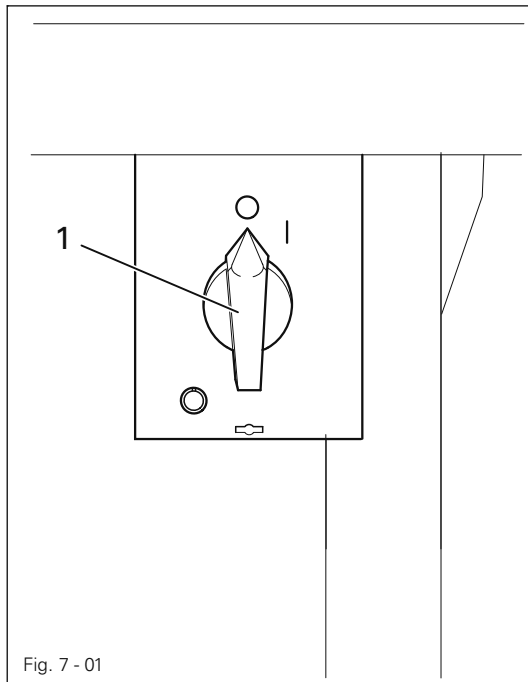

#### Machines with motor P45 PD2-L + P74 ED-L

- The power supply to the machine is switched on or off by turning switch 1.

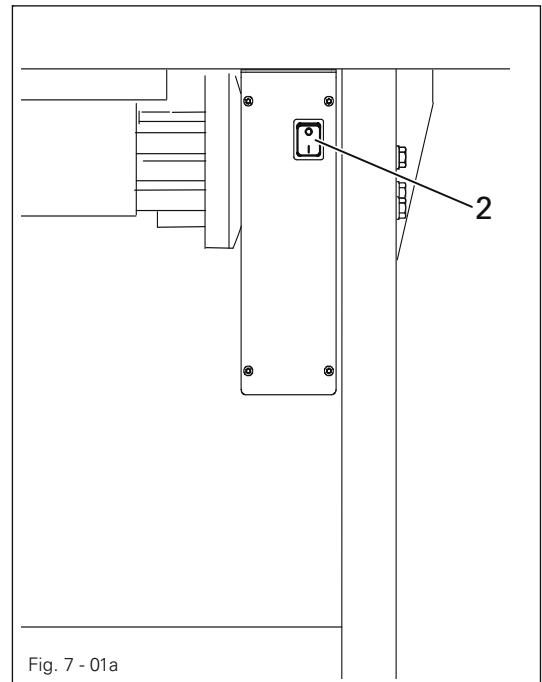

#### Machines with motor AB 321 + PF 321

- Operate main switch 2 to switch the machine on or off.

### 7.02 Sewing lamp switch (option)

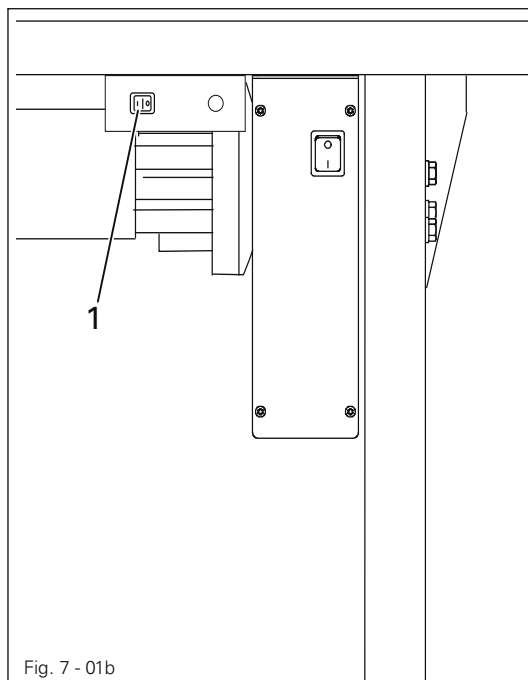

- Switch the sewing lamp, which is integrated in the machine head, on or off by operating switch 1.

7.03 Pedal

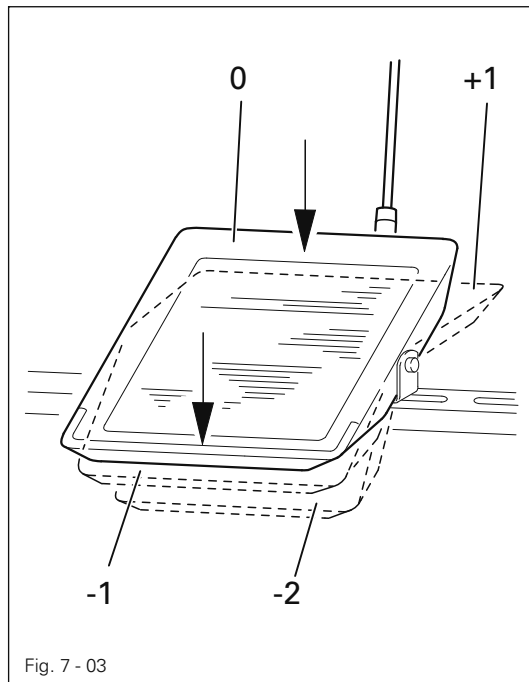

Fig. 7 - 03

- With the on/off switch on
  - 0 = Machine stop
  - +1 = Sew
  - 1 = Raise presserfoot
  - 2 = Trim thread  
(on machines with thread trimmer)

## 7.04 Keyboard on machine head (only on the PFAFF 2235 PLUS)

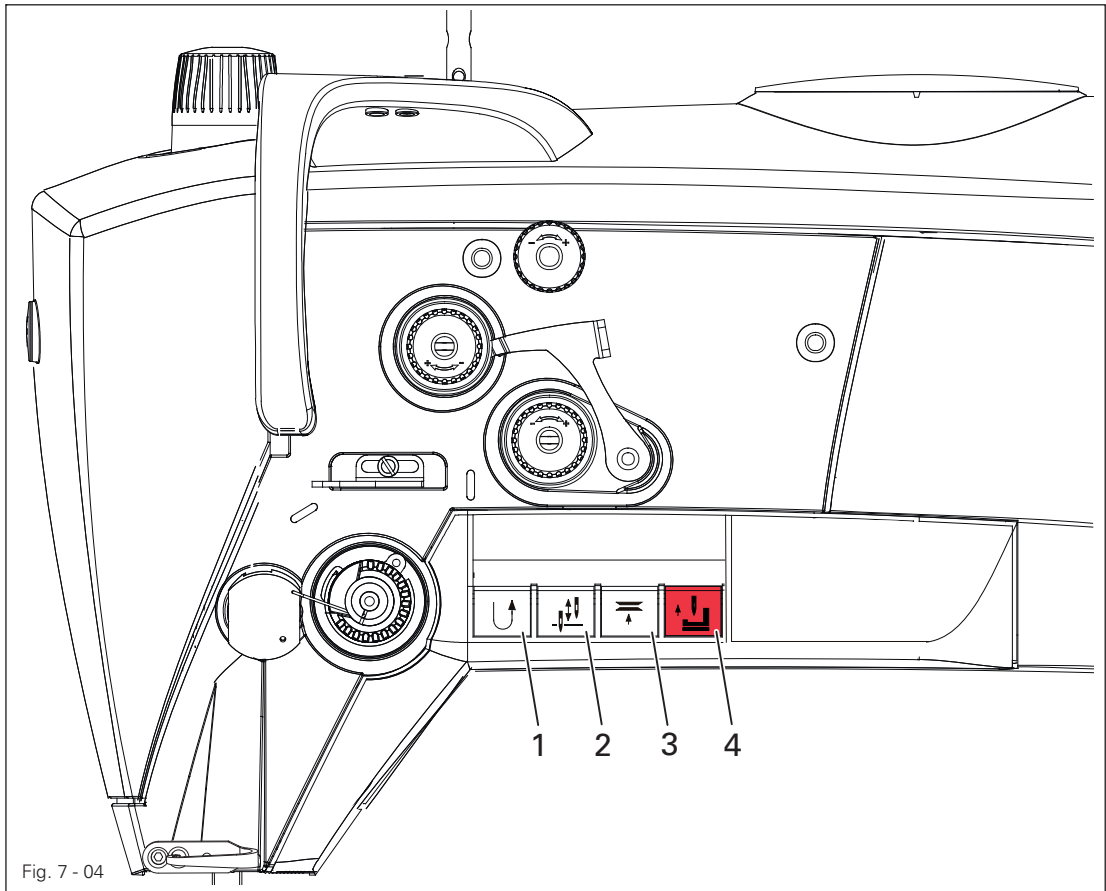

Fig. 7 - 04

- The machine as a keyboard with 4 keys to activate different functions.
- When the keys 1 – 4 are operated on the standard version, the functions listed below are carried out.



Key 1: **Reverse sewing or intermediate backtacks during the seam.**

*(For drive system P45 PD2-L = standard)*

*For drive system AB 321, the value 16 is set under parameter 244 (= standard).*



Key 2: **Needle position change**

This button can have the **following functions** assigned depending on the drive system implemented and by way of changes to the parameter values:

P45 PD2-L		AB 321	
Parameter	Function	Parameter	Function
446	1 = needle raised without trimming	242	01 = Change needle position (standard)
	2 = needle position change		02 = needle up without trimming
	3 = single stitch		03 = Single stitch
	4 = not allocated		17 = inversion
	5 = tack inversion		96 = Backtack suppression (all autom. backtack deactivated)
	6 = tack suppression		97 = Single stitch reverse
			98 = Not used





Key 3: This button can have the **following functions** assigned depending on the drive system implemented and by way of changes to the parameter values:

P45 PD2-L		AB 321	
Parameter	Function	Parameter	Function
748	1 = threading aid + needle raised without trimming 2 = needle position change 3 = single stitch 4 = not allocated 5 = tack inversion 6 = tack suppression	249	91 = Needle up without trimming (= standard) 01 = Change needle position 03 = Single stitch 17 = inversion 96 = Backtack suppression (all autom. backtack deactivated) 97 = Single stitch reverse 98 = Not used



Key 4: **EMERGENCY KEY.**

( needle is raised without trimming, the thread clamp is opened, the thread tension is released, the presser foot raised and the motor start inhibitor activated)

**Deactivation the motor safety lock**

*For drive system P45 PD2-L - click the button 'Scroll'.*



*For drive system AB 321 - click the button 'E' (under parameter 247, the value 24 is set = standard)*



The method for setting parameters is described in the settings manual, and may only be carried out by certified professionals!

## 7.05 Keyboard on machine head (only on the PFAFF 2235 PREMIUM)

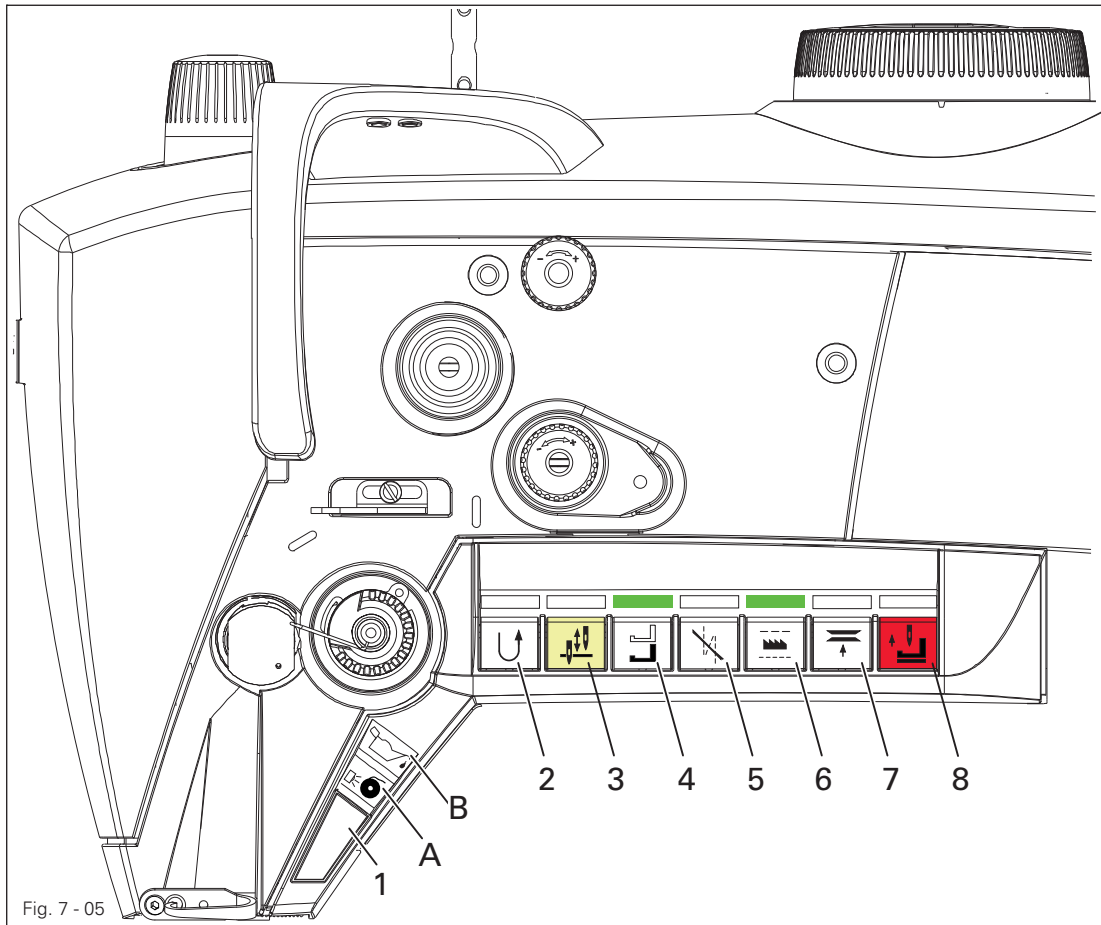

- The machine has a keyboard with 8 keys to activate different functions.
- In the keys 2 – 7 there are yellow LEDs. These shine when the respective function has been allocated to key 1.
- Green LEDs are located above the keys 2 - 7. These shine when the function has been activated.
- Above key 1 there are two symbol lamps.  
Lamp A indicates the status of the bobbin thread control.  
Lamp B shines when the minimum level of the oil supply has been reached.
- When the keys 1 – 8 are operated, the functions listed below are carried out.

**Key 1:** The functions of the keys 2 - 7 can be allocated to this key.  
To program key 1, simultaneously press one of the keys 2 - 7 and key 1 for approx. **3 seconds**. The function of the selected key is taken over and the yellow LED in this key lights up  
(For drive system P74 ED-L = standard)  
For drive system PF 321, the value **94** is set under parameter **840** (= standard).



**Key 2:** **Reverse sewing or intermediate backtacks during the seam.**  
(On drive system P74 ED-L under Parameter **634** other functions can be assigned to this key: ON = Feed adjustment when machine has stopped and when machine is running (standard)  
OFF = Feed adjustment only when machine is running  
For drive system PF 321, the value **16** is set under parameter **841** (= standard).



**Key 3: Needle position change**

This button can have the **following functions** assigned depending on the drive system implemented and by way of changes to the parameter values:

P74 ED-L		PF 321	
Parameter	Function	Parameter	Function
695	0 = Off 1 = needle raised without trimming 2 = needle position change (standard) 3 = single stitch 4 = single stitch in reverse 5 = moving forwards to needle position step by step 6 = programmable tack on / off	842	0 = Function off 01 = Needle up without trimming 02 = Change needle position (standard) 03 = Single stitch 20 = Step-by-step approach to a needle position forward 95 = Offset multi-backtack 96 = Backtack suppression (all autom. backtack deactivated) 97 = Single stitch reverse 98 = Not used



**Key 4: Calling up the pre-selected top feed lift.**

(Diode on = high lift, diode off = low lift)..

This button can have the **following functions** assigned depending on the drive system implemented and by way of changes to the parameter values:

P74 ED-L		PF 321	
Parameter	Function	Parameter	Function
401	0 = Off 1 = when key pressed constant second stroke (standard) 2 = second stroke only as long as key pressed If this key is operated, the second voltage is switched on This function can be switched off under Parameter 764	843	0 = Off 01 = With button pressed constantly, 2nd lift (standard) 02 = 2nd lift only while button is pressed 14 = Stroke adjustment (Flip Flop 1) with speed limit N10 (Parameter 137 must be set to "On")



**Key 5: Bartack suppression for one bartack.**

This button can have the **following functions** assigned depending on the drive system implemented and by way of changes to the parameter values:

P74 ED-L		PF 321	
Parameter	Function	Parameter	Function
780	0 = Off 1 = tack inversion once (standard) 2 = tack suppression (all tacks switched off) 3 = reverse move to needle position step by step 4 = edge trimmer on / off 5 = programmable tack on / off	844	17 = Backtack inversion, single (standard) 21 = Step-by-step approach to a needle position reverse 95 = Offset multi-backtack 96 = Backtack suppression (all autom. backtack deactivated) 97 = Single stitch reverse 98 = Not used



**Key 6: Calling up the pre-set stitch length**

Diode on = large stitch length, diode off = small stitch length.

This button can have the **following functions** assigned depending on the drive system implemented and by way of changes to the parameter values:

P74 ED-L		PF 321	
Parameter	Funktion	Parameter	Funktion
786	Function = Standard This function can be switched off under Parameter 786.	845	22 = Speed limitation n11 , Flip Flop 2 (Parameter 186 must be set to "On".



**Key 7:** If this key is operated, the second thread tension is switched on.

If this key is pressed for longer than about **2** seconds, the machine moves to the threading position - the needle is raised and the motor start inhibitor is activated (sewing threads are not trimmed).

If the key is operated again, the motor start inhibitor is deactivated again

*(For drive system P74 ED-L = standard)*

*For drive system PF 321, the value 93 is set under parameter 846 (= standard).*



**Key 8: EMERGENCY KEY**

Needle is raised without trimming, the thread clamp is opened, the thread tension is released, the presser foot raised and the motor start inhibitor activated.

**Deactivation the motor safety lock**



*For drive system P74 ED-L - click the button 'Scroll'.*

*For drive system PF 321 - click the button 'E' (under parameter 847, the value 24 is set = standard)*



The method for setting parameters is described in the settings manual, and may only be carried out by certified professionals!

7.06 **Knee lever** (only on the PFAFF 2235 BASIC)

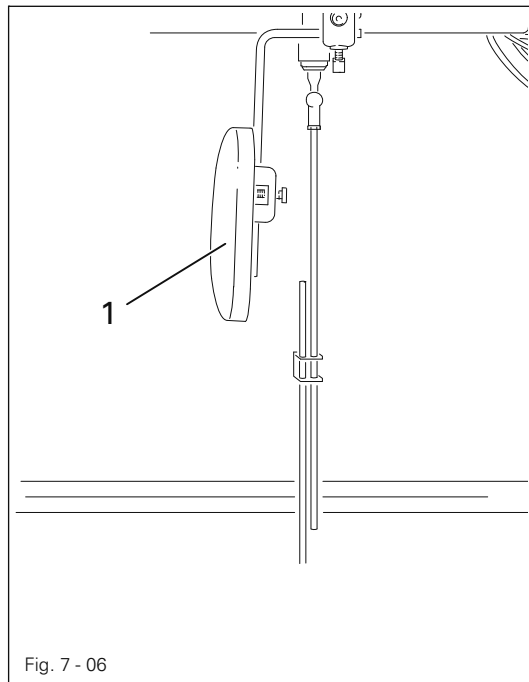

- By pressing the knee lever 1 in the direction of the arrow, the presser foot is raised.

7.07 **Knee switch** (only as an option on the PFAFF 2235 PFAFF PLUS)

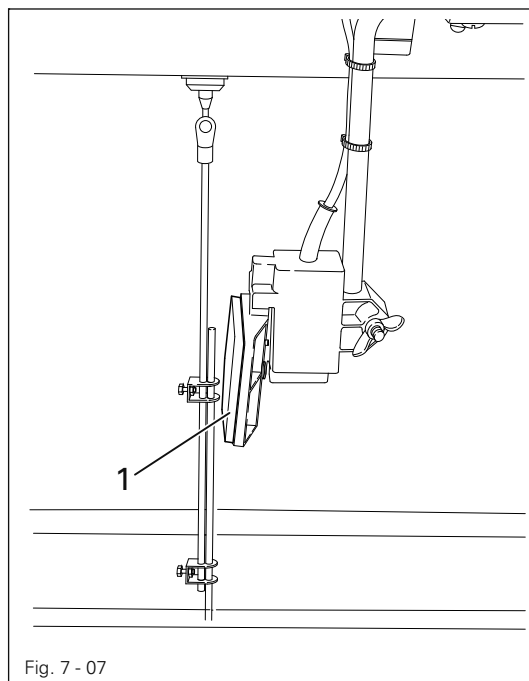

- Operate knee switch 1 to raise the sewing foot.

## 7.08 Lever for lifting the presser foot

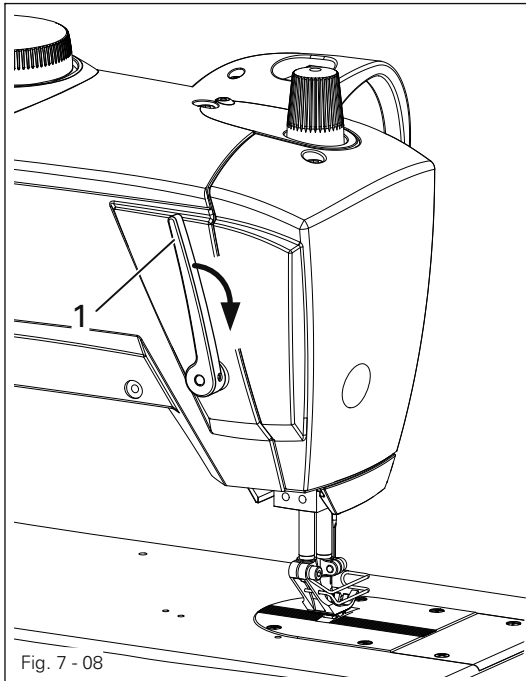

- The sewing foot can be lifted by raising lever 1.

## 7.09 Adjusting the stitch length / Reverse feed lever (PFAFF 2235 BASIC + PLUS)

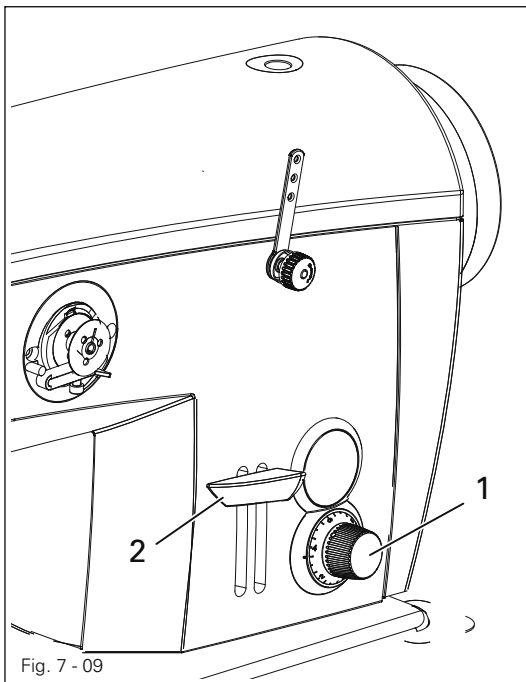

- Adjustment wheel 1 is used to pre-select the stitch length.
- As long as the reverse feed lever 2 is pressed during the sewing operation, the machine sews in reverse.

7.10 Adjusting the stitch length / Reverse feed lever (PFAFF 2235 PREMIUM)

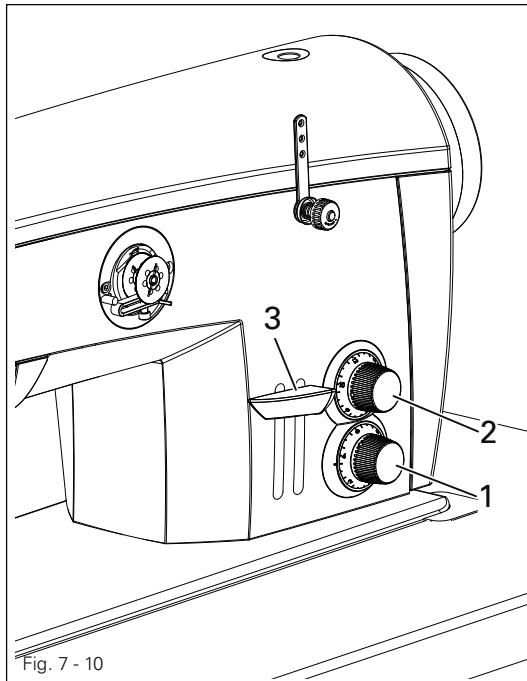

- Two different stitch lengths can be pre-selected on the thumb wheels 1 and 2.
- The adjustment can be made by turning the thumb wheels.
- The larger stitch length is set on thumb wheel 1, and the smaller stitch length on thumb wheel 2.
- Use key 4 to call up the pre-selected stitch lengths, see Chapter 7.05 Keyboard on machine head.
- As long as the reverse feed lever 3 is pressed during the sewing operation, the machine sews in reverse.

7.11 Adjusting the top feed stroke (on the PFAFF 2235 BASIC + PLUS)

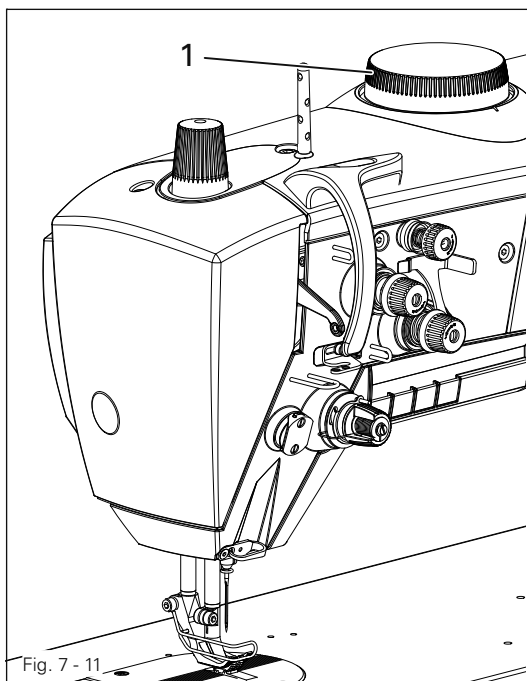

- The top feed stroke can be adjusted by turning knob 1.

## 7.12 Adjusting the top feed stroke (on the PFAFF 2235 PREMIUM)

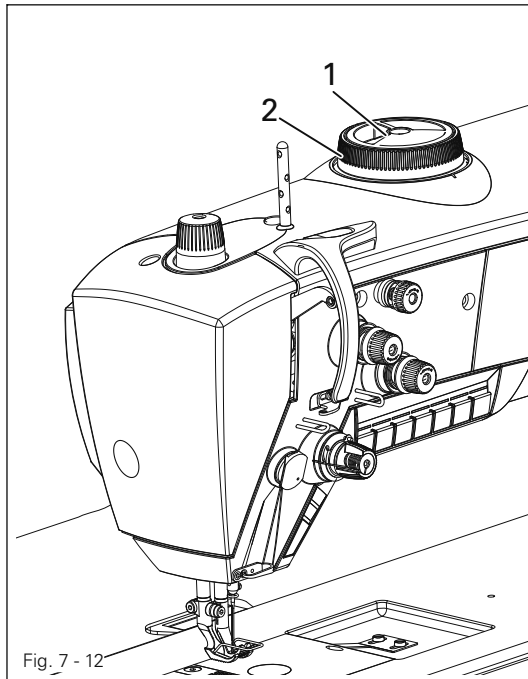

- The large top feed lift can be set by turning thumb wheel 1, and the small top feed lift by turning thumb wheel 2.
- Use key 4 to change between the two top feed lift settings (see Chap. 7.05 Keyboard on machine head).

## 7.13 Switchable needle thread tension

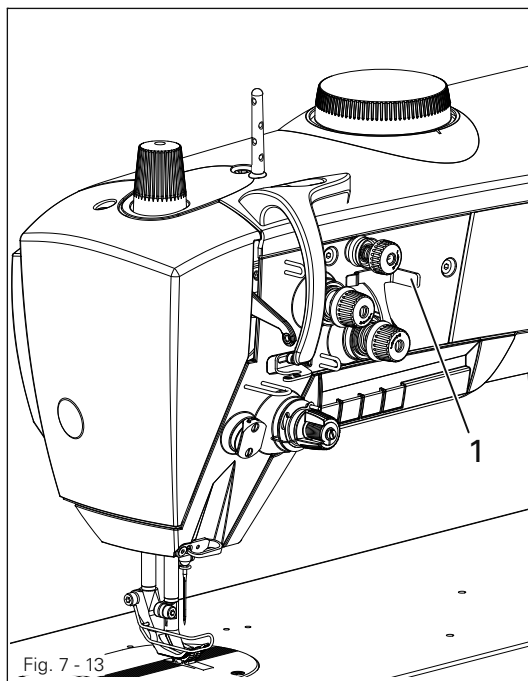

- The needle thread tension can be increased by turning lever 1 to the right.



### 7.14 Control panel

The description can be found in the separate instruction manual for the motor.

### 7.15 Safety coupling (optional)

- The safety coupling in the handwheel is set to automatically unlatch in case of a thread jam to prevent damage to the gripper.
- Once the thread jam has been removed, the coupling can be reset on the handwheel by turning the wheel.

8

## Preparation



All regulations and instructions in this Instruction Manual are to be observed!  
Special attention is to be paid to the safety regulations!



All preparation work is only to be carried out by appropriately trained personnel.  
Before all preparation work, the machine is to be separated from the electricity supply by removing the plug from the mains or switching off the On/Off switch!

8.01

## Inserting the needle

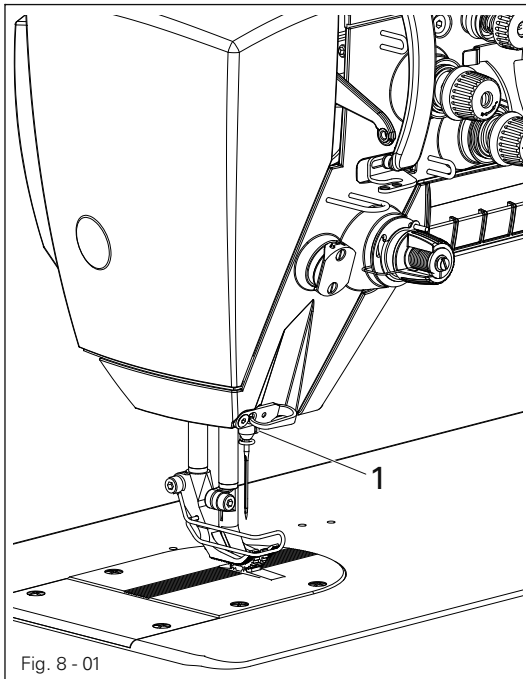

Fig. 8 - 01



Switch off the machine!  
Danger of injury due to unintentional starting of the machine!



Only use needles from the system intended for the machine, see Chapter 3 Specifications.

- Raise needle bar.
- Loosen screw 1 and insert needle until you feel it stop.
- The long needle-groove must be facing left.
- Tighten screw 1.

## 8.02 Winding the bobbin thread, regulating the winder tension

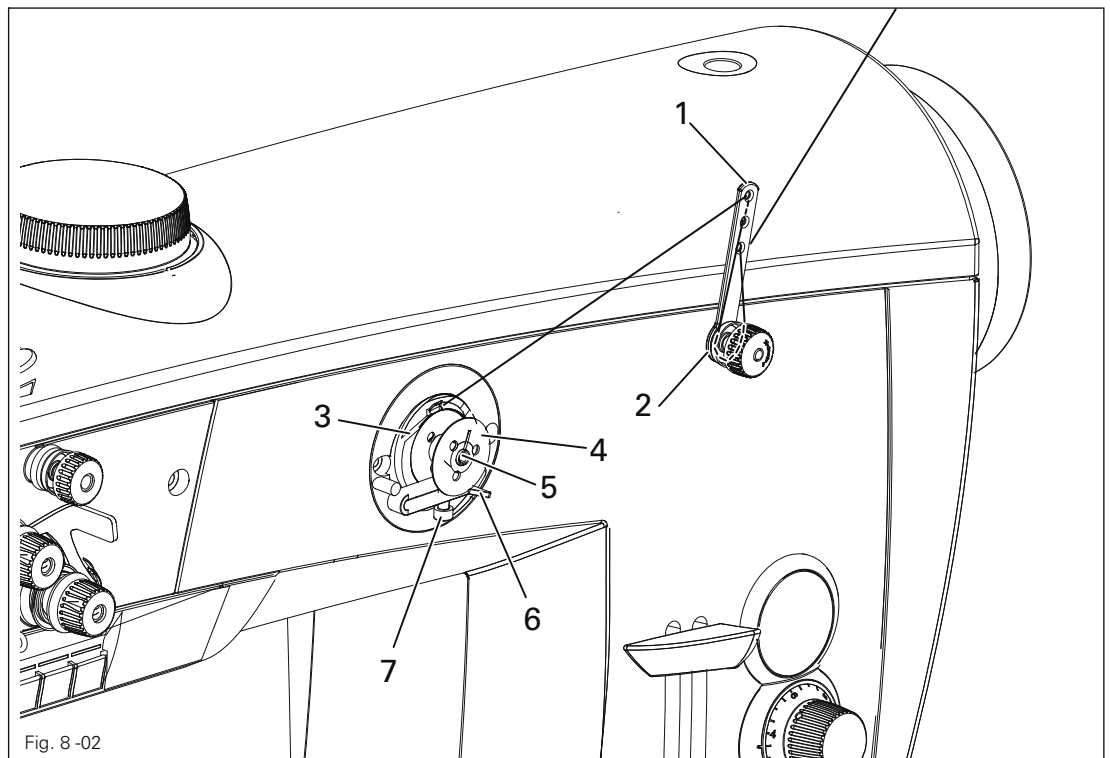

- Draw the thread from the reel stand through guide hole 1 into the bobbin winder tension unit 2 and then behind the thread clamp 3.
- Cut off the thread in thread clamp 3. The thread is retained.
- Place empty bobbin 4 on the bobbin winder spindle.
- To switch on the bobbin winder, push up lever 6.



The bobbin is wound during sewing.

- The bobbin winder stops automatically, when the bobbin 4 is filled sufficiently.
- Remove full bobbin 4 and cut off the thread in thread clamp 3.
- The tension of the thread on bobbin 4 can be adjusted on the bobbin winder tension unit 2.
- The volume of thread on bobbin 4 can be adjusted with screw 7.

## 8.03 Removing / Inserting the bobbin case

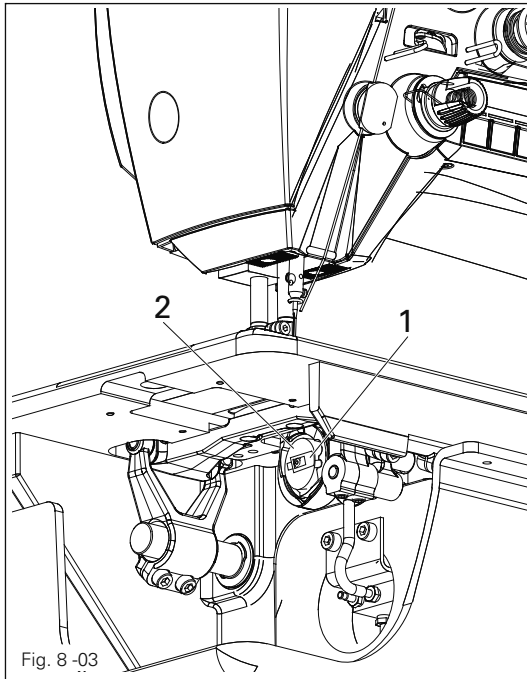

Switch off the machine!  
Danger of injury due to unintentional starting of the machine!

### Removing the bobbin case:

- Raise latch 1 and remove bobbin case 2.

### Inserting the bobbin case:

- Press bobbin case 2 until you feel it snap into the bobbin case base.

## 8.04 Inserting the bobbin case / Adjusting the bobbin thread tension

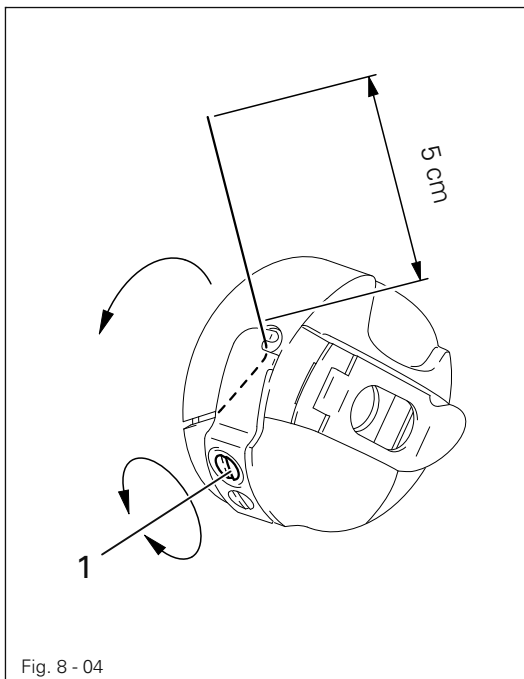

- Insert the bobbin into the bobbin case.
- Pass the thread through the slot under the spring according to Fig. 8 - 04.
- Pass the thread through the notch.
- Adjust the thread tension by turning screw 1.



When the thread is pulled, the bobbin must rotate in the direction of the arrow.

8.05 Threading needle thread/adjusting needle thread tension

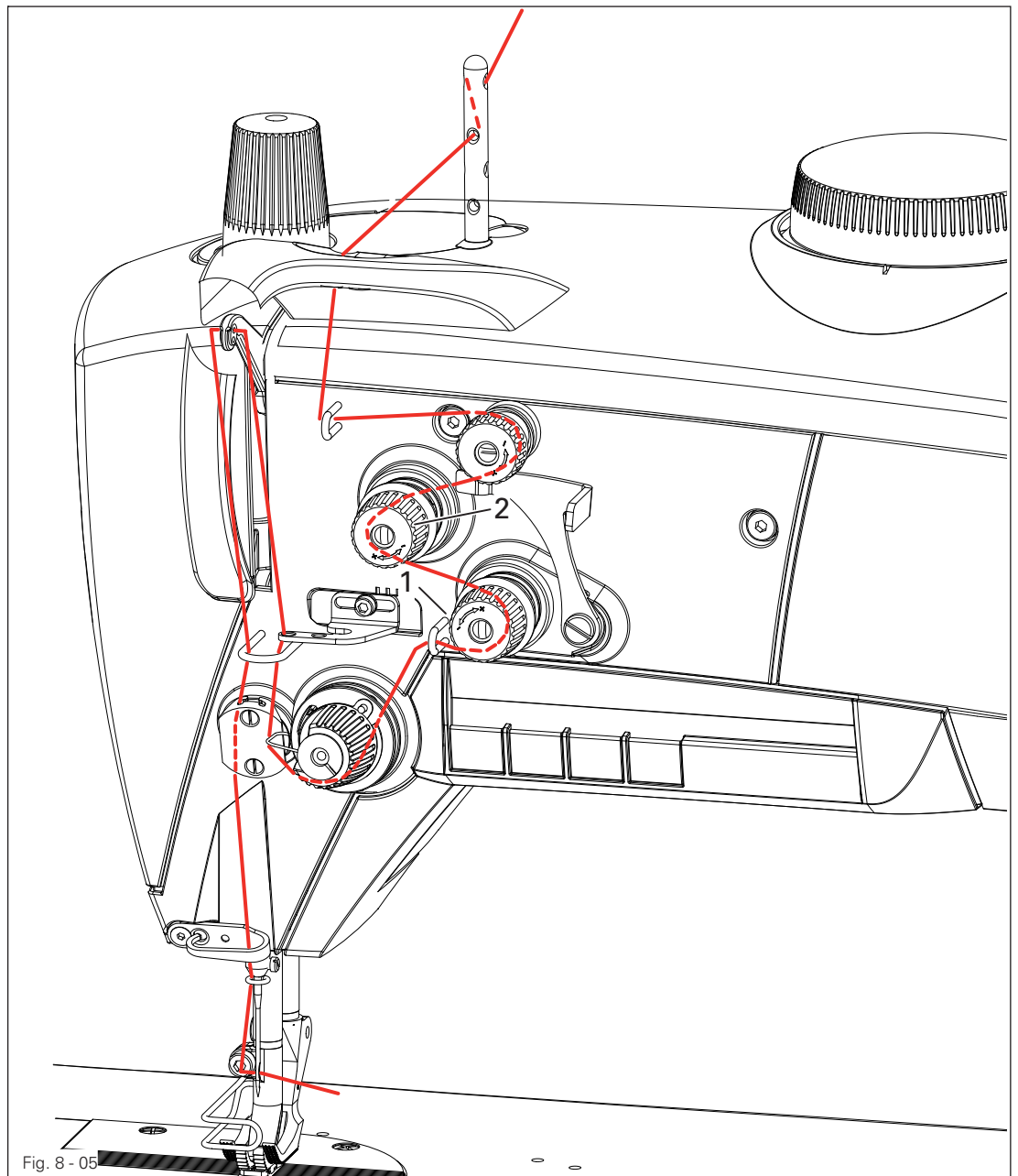

Switch off the machine!  
 Danger of injury due to unintentional starting of the machine!

- Thread the machine as shown in Fig. 8 - 05.
- Regulate the needle-thread tension by turning milled screw 1 or 2.

8.06 Setting the bobbin thread control function by reverse stitch counting



The description can be found in the separate instruction manual for the motor.

## 9 Care and maintenance

### 9.01 Servicing and maintenance intervals

Clean the hook compartment .....	Daily, several times if in continuous use
Check the oil level .....	Daily, before starting the machine
Check/adjust the air pressure .....	Daily, before starting the machine
Clean the filter of the air filter/lubricator .....	As required



These maintenance intervals are calculated for the average running time of a single shift operation. If the machine is operated more than this, shorter intervals are recommended.

### 9.02 Cleaning the machine

The cleaning cycle required for the machine depends on following factors:

- Single or several shift operation
- Amount of dust resulting from the workpiece

It is therefore only possible to stipulate the best possible cleaning instructions for each individual case.



For all cleaning work the machine must be disconnected from the mains by switching off the on/off switch or by removing the mains plug!  
Danger of injury if the machine suddenly starts up .

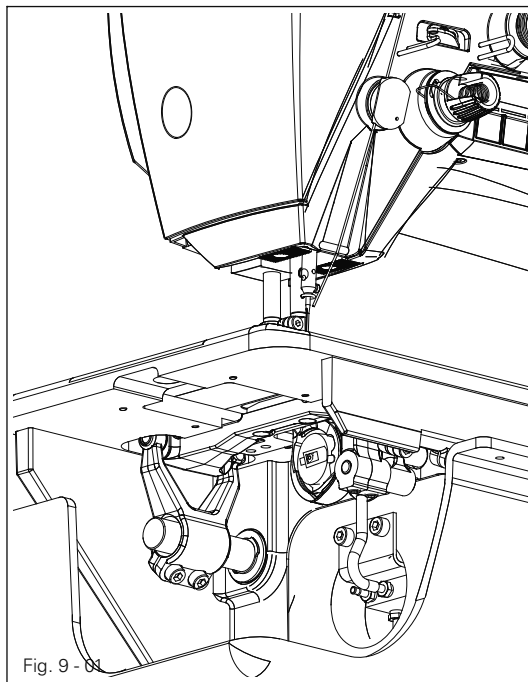

Fig. 9 - 01

To avoid breakdowns, the following cleaning work is recommended for single shift operation:

- Tilt the machine back onto the sewing head support.
- Clean the hook and hook compartment daily, more often if in continuous operation.



Return the machine to its upright position using **both** hands!  
Danger of injury by crushing between the edge of the machine and the table top!

9.03 Lubricating

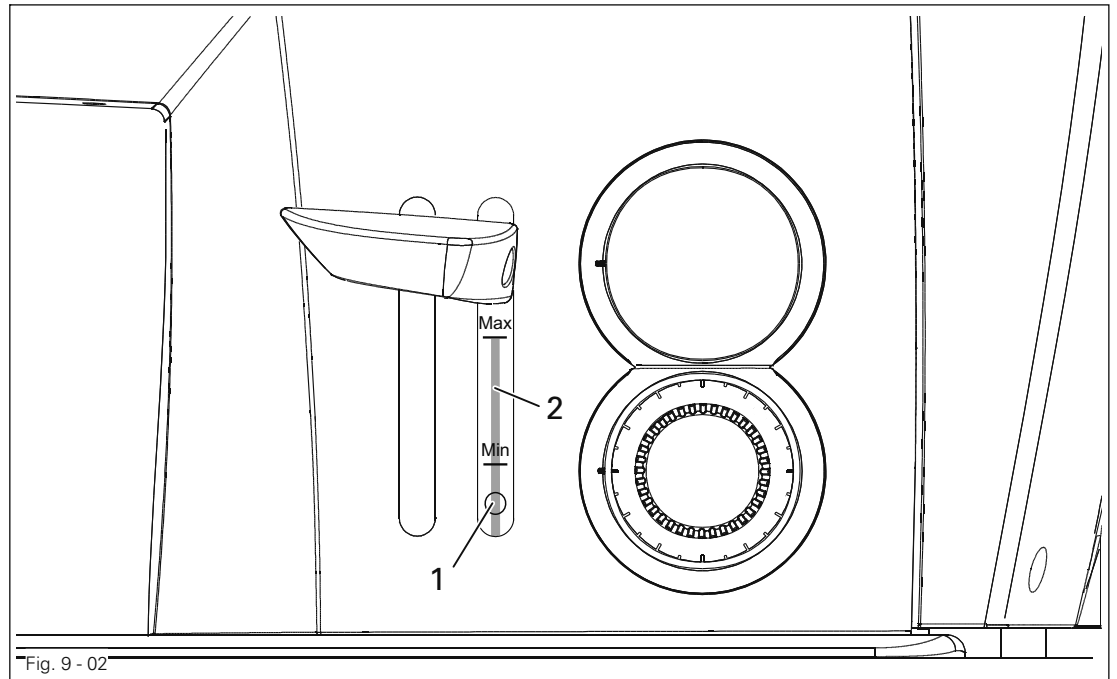

Before commissioning the machine, fill in oil through hole 1 until the oil level indicator 2 is at the "MAX" marking.



**PFAFF 2235 BASIC and PFAFF 2235 PLUS**

Check the oil level daily before starting the machine!

The level of the oil in indicator 2 must not sink below the "MIN" marking and not exceed the "MAX" marking.

If required, fill oil into the tank through hole 1.



**PFAFF 2235 PREMIUM**

The oil level is controlled by sensor.

When the minimum oil level is reached, key B on the machine head shines red (see Chapter 7.04 Keys on the machine head).

If required, fill oil into the tank through hole 1.

Oil level indicator 2 must not exceed the "MAX" marking.

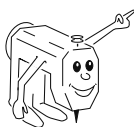

Only use oil with a medium viscosity of 22.0 mm<sup>2</sup>/s at 40° C and a density of 0.865 g/cm<sup>3</sup> at 15°C!

We recommend PFAFF sewing-machine oil, part No. 280-1-120 144.

### 9.04 Checking/regulating the air pressure

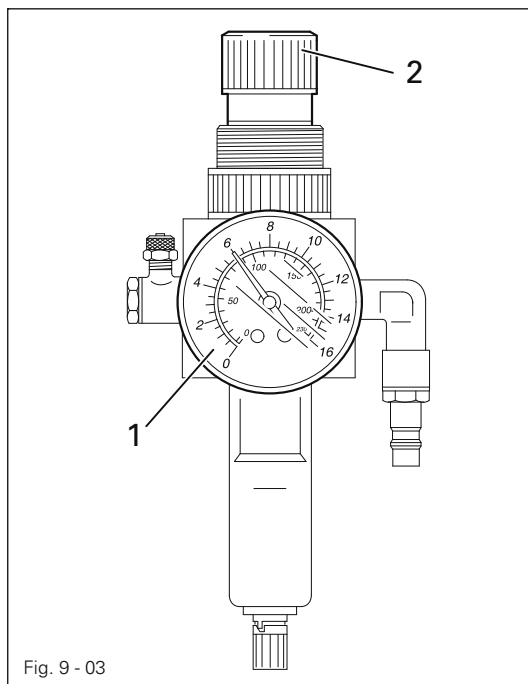

- Check the air pressure on gauge 1 every time before operation.
- Gauge 1 must show a pressure of 6 bar.
- Regulate this pressure if required.
- To do so, pull knob 2 up and turn it accordingly.

### 9.05 Emptying/cleaning the water bowl of the air filter/regulator

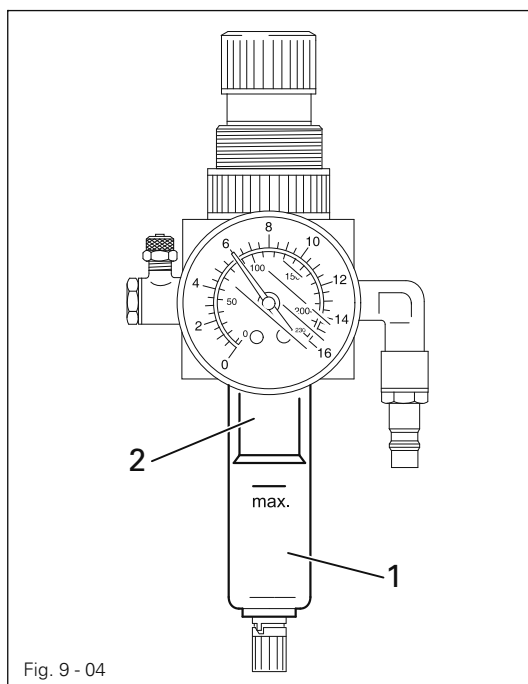

Switch off the machine.  
Disconnect the air hose at the  
air filter/regulating unit.

#### Emptying the water bowl

- Water bowl 1 empties itself automatically when the air hose is disconnected from the air filter/regulator.

#### Cleaning the filter

- Unscrew water bowl 1 and take out filter 2.
- Clean the filter with compressed air or with isopropyl-alcohol, part number 95-665735-91.
- Screw in filter 2 and screw on water bowl 1.



10

Wearing parts

This is a list of the most important wearing parts.

A detailed parts list for the complete machine is included with the accessories.

In case of loss, the parts list can be downloaded from the internet address [www.pfaff-industrial.com/pfaff/de/service/downloads](http://www.pfaff-industrial.com/pfaff/de/service/downloads) As an alternative to the internet download the parts lists can also be ordered in book form under part no. 296-12-19 217.

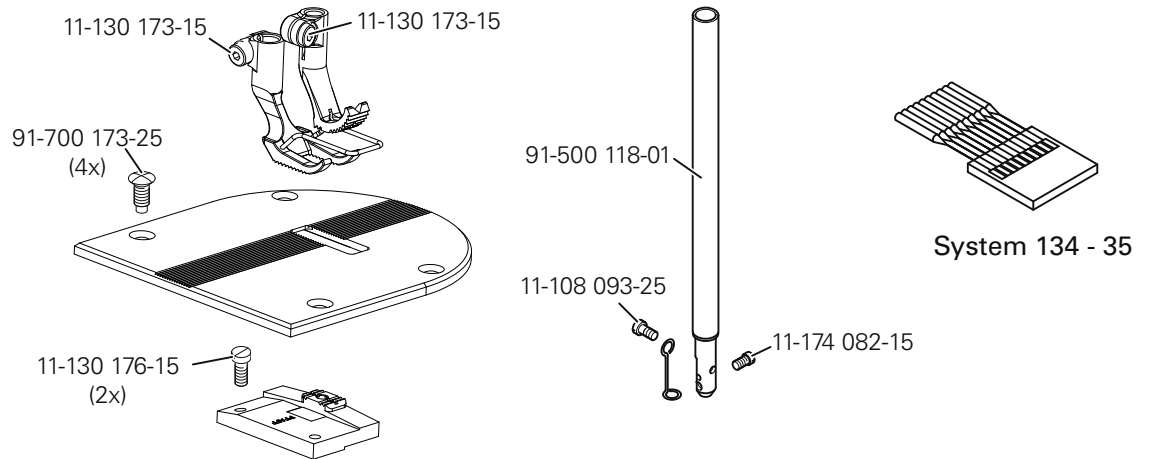

91-500 570-91 C  
 91-500 580-91 C/D

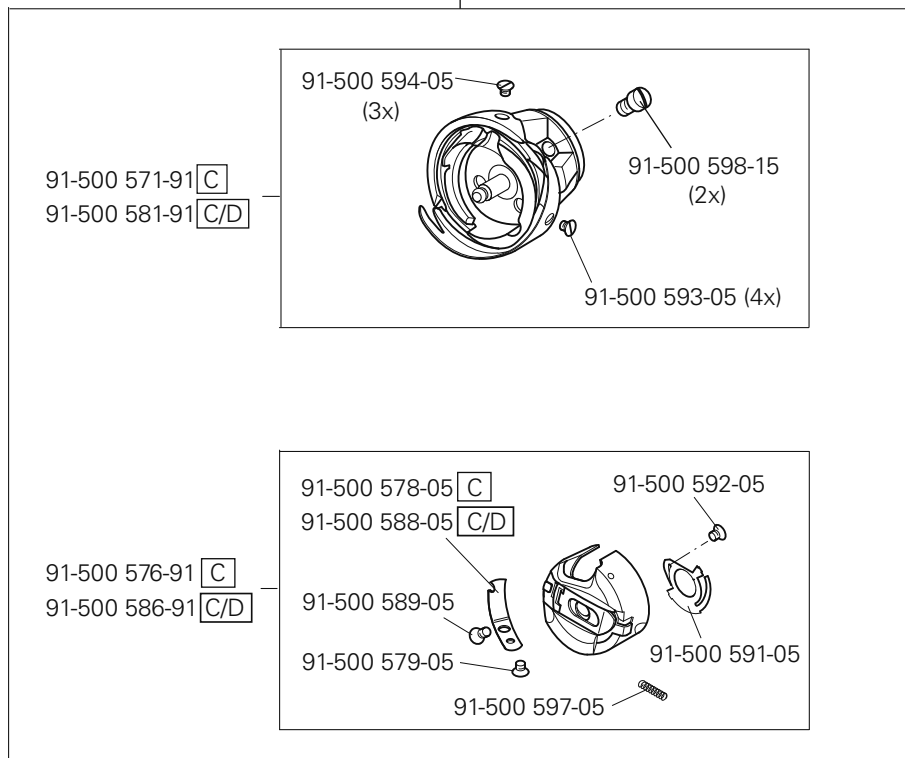

91-500 590-05

C = Version  
C/D = Version

# Wearing parts

91-500 460-05

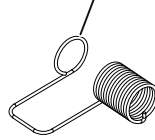

99-137 520-05



91-500 251-05

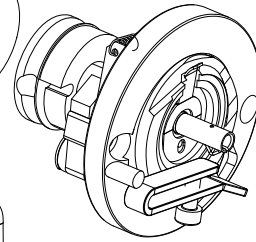

## -900/91

91-500 319-05



12-360 040-05 (0,1 mm)



12-360 041-05 (0,15 mm)



91-500 318-05



11-225 175-05 (2x)



91-500 337-05







**Europäische Union**  
Wachstum durch Innovation – EFRE



## PFAFF Industriesysteme und Maschinen AG

Hans-Geiger-Str. 12 - IG Nord  
D-67661 Kaiserslautern

Phone: +49-6301 3205 - 0

Fax: +49-6301 3205 1386

E-mail: [info@pfaff-industrial.com](mailto:info@pfaff-industrial.com)